

DOCUMENT RESUME

ED 117 282

UD 015 686

AUTHOR Morisseau, James J.  
 TITLE The Mini-School Experiment. Restructuring Your School: A Handbook.  
 INSTITUTION New York Urban Coalition, N.Y.  
 PUB DATE Nov 75  
 NOTE 170p.  
 AVAILABLE FROM New York Urban Coalition, 55 Fifth Avenue, New York 10014 (\$3.95)

EDRS PRICE MF-\$0.76 HC-\$8.24 Plus Postage  
 DESCRIPTORS Alternative Schools; \*Change Strategies; Disadvantaged Youth; Educational Alternatives; Educational Change; \*Educational Experiments; Educational Innovation; Educational Methods; Experimental Schools; Guidelines; \*High School Design; \*High School Organization; High Schools; High School Students; Manuals; Public Schools; Resource Guides; Secondary Education; Urban Schools  
 IDENTIFIERS Mini Schools; New York (Manhattan); \*Project Haaren

ABSTRACT

This book documents the Haaren Project, believed to be the only one involving the conversion of an entire existing high school to a mini-school format. It outlines the shortcomings of the existing system that gave rise to the alternative-school movement, traces the history of the early alternative schools citing their successes, shortcomings and failures, and discusses the reasoning behind the project. The future of this mini-school project, along with the future of alternative education and school renewal in general and the potential impact of the alternative-school movement on established school systems particularly in the inner city is addressed last. The concluding chapter is presented as a guide for educators and community groups interested in launching their own alternative-school programs based on the mini-school approach and the processes involved. It offers a step-by-step "road map" covering such areas as planning organization, management, financing, administration, staffing, day-to-day operation, involvement of the business community, and facilities planning and acquisition.  
 (Author/AM)

\*\*\*\*\*  
 \* Documents acquired by ERIC include many informal unpublished \*  
 \* materials not available from other sources. ERIC makes every effort \*  
 \* to obtain the best copy available. Nevertheless, items of marginal \*  
 \* reproducibility are often encountered and this affects the quality \*  
 \* of the microfiche and hardcopy reproductions ERIC makes available \*  
 \* via the ERIC Document Reproduction Service (EDRS). EDRS is not \*  
 \* responsible for the quality of the original document. Reproductions \*  
 \* supplied by EDRS are the best that can be made from the original. \*  
 \*\*\*\*\*

UD015686

U.S. DEPARTMENT OF HEALTH,  
EDUCATION & WELFARE  
NATIONAL INSTITUTE OF  
EDUCATION

THIS DOCUMENT HAS BEEN REPRO-  
DUCED EXACTLY AS RECEIVED FROM  
THE PERSON OR ORGANIZATION ORIGIN-  
ATING IT. POINTS OF VIEW OR OPINIONS  
STATED DO NOT NECESSARILY REPRESENT  
OFFICIAL NATIONAL INSTITUTE OF  
EDUCATION POSITION OR POLICY

# THE MINI-SCHOOL EXPERIMENT

## Restructuring Your School: A Handbook

by James J. Morisseau,

New York Urban Coalition  
New York, N.Y.  
November 1975

55 Fifth Avenue  
New York, N.Y. 10014

741-6000

ED117282

015-686



Full Text Provided by ERIC

## NEW YORK URBAN COALITION BOARD OF DIRECTORS

Donald H. Elliott  
*Chairman*

Arthur H. Barnes  
*President*

George W. Dennis  
*Treasurer*

### BOARD OF DIRECTORS

Sol C. Chaikin  
*ILGWU*

Humberto Cintron  
*Realidades*

Morris D. Crawford, Jr.  
*Bowery Savings Bank*

William M. Ellinghaus  
*New York Telephone Co.*

Moe Foner  
*Local 1199,  
Drug and Hospital Union*

Clifton C. Garvin, Jr.  
*Exxon Corporation*

Bernard Gifford  
*NYC Board of Education*

Edwin Greenidge

James E. Gunther  
*Transfiguration Lutheran Church*

Andrew Heiskell  
*Time Incorporated*

Sam Kovenetsky  
*Local 1-S,  
Department Store Workers' Union*

Ugo Lisi  
*Banco de Ponce*

J. Bruce Llewellyn  
*FEDCO Foods Corp.*

Alton G. Marshall  
*Rockefeller Center, Inc.*

David B. McCall  
*McCaffrey and McCall*

H. Carl McCall  
*State Senator*

Harriet Michel  
*New York Foundation*

Herbert L. Miller

Josephine Nieves  
*Brooklyn College*

Jack John Olivero  
*AT&T*

Walter H. Page  
*Morgan Guaranty Trust Co.*

Ernesta G. Procope  
*Bowman Co., Inc. Insurance*

Walter N. Rothschild, Jr.  
*National Urban Coalition*

Andrew G. C. Sage, II  
*Lehman Brothers, Inc.*

Orville H. Schell, Jr.  
*Hughes, Hubbard & Reed*

J. Henry Smith  
*Economic Development Council*

Thomas C. Theobald  
*First National City Bank*

William Toles  
*ITT Continental Baking Co.*

John Torres  
*Metro Spanish Merchants Food Co-op,  
Inc.*

Rafael Valdivieso  
*Community School District #1*

Cecil Ward  
*Local 32B,  
Service-Employees' Union*

Herbert B. Woodman  
*Inmont Corporation*

Listed below are the NYUC Board of Directors who served during the period covered in this book.

Eyelina Antonetty  
United Bronx Parents, Inc.

Humberto Aponte  
Council Against Poverty

Harry Von Arsdale  
New York City Central Labor  
Council

William Bartel  
Celanese Corp.

Ismael Betancourt  
National Urban Coalition

Marshall P. Bissell  
New York Life Insurance Co.

Eugene S. Callender  
New York Urban Coalition

Wilbur Daniels  
International Ladies' Garment  
Workers' Union

Leon J. Davis  
Local 1199  
Drug & Hospital Union

William H. Donaldson  
Donaldson, Lusk & Jenrette, Inc.

Frank Espada  
New York Urban Coalition

Matthew Guinan  
Transport Workers Union of  
America

William Haddad  
United States R&D Corp

Najeeb E. Halaby  
Pan American World Airways

Christian A. Herter Jr.  
Mobil Oil Corp.

Roy Innis  
CORE

W.H. James  
New York News, Inc.

William A. Jones  
Bethany Baptist Church

Gustav L. Levy  
Goldman, Sachs and Co.

Charles F. Luce  
Consolidated Edison Co. of N.Y.

Lincoln O. Lynch  
New York Urban Coalition

Dunbar McLaurin  
Universal National Bank

Charles W.V. Meares  
New York Life Insurance Co.

Peter Ottley  
Local 144  
Hotel & Allied Services Employee  
Union

Roswell B. Perkins, Esq.  
DeBevoise, Plimpton, Lyons &  
Gates

Alan Pifer  
Carnegie Corp. of New York

Bertram A. Powers  
Local 6  
New York Typographical Union

Caros Ramos  
C.U.N.Y.

Florence Rice  
Harlem Consumer Education  
Council, Inc.

Howard D. Samuël  
Amalgamated Clothing Workers

T. George Silcott  
N.Y.U. School for Social Work

Irving Stern  
Local 342  
AFL-CIO Amalgamated Meat  
Cutters  
and Retail Food Store Employees

David Spencer  
I.S. 201 Planning Board Complex

Franklin A. Thomas  
Bedford-Stuyvesant Restoration

Robert V. Tishman  
Tishman Realty & Construction  
Co.

Hector Vazquez  
Puerto Rican Forum

Ted Velez  
East Harlem Tenants Council

Timothy Vincent  
Bedford-Stuyvesant Sports

Saul Wallen  
New York Urban Coalition

Thomas R. Wilcox  
First National City Bank

John A. Willis  
Union Carbide Corp.

The following were members of the Education Department staff, New York Urban Coalition, during all or part of the duration of the Haaren mini-school project.

Rosie Carvin	Administrative Secretary
Joanne Darby	Secretary
Chuck Dickinson	School-Coalition Liaison
Robyn Govan	Research Assistant
Lynn Gray	Director of Education
Pat Griffin	Secretary, Streetworker Program
Louis McCagg	Program Manager
Linda McGough	Administrative Secretary
Nate Moore	Editor, Mini-School News, 1973-5
Calvin Ramsey	Director of Streetworkers
Bobby Rogers	Supervisor of Streetworkers
Yolanda Schuschny	Planning and Budget Associate
Joan Strauss	Editor, Mini-School News, 1971-73
Norma Valdez	Secretary, Business Representatives' Office

The following were Business Representatives loaned to the Education Program for the Haaren project.

Anthony Christ	New York Telephone
Wilbert Davis	IBM
Anthony O'Brien Grazioso	Port Authority of New York & New Jersey
William Hall	Touche Ross
Richard Kameron	Exxon
Atiba Kee	Western Electric
Edward McCormack	Equitable Life Assurance Society
Napoleon Rhodes	Atlantic Richfield
Emil Schell	IBM
Albert Simon	Port Authority of New York & New Jersey

## PRIVATE SECTOR SUPPORT

The following corporations, foundations, and institutions provided assistance to the Coalition either in the form of financial support, staff time, advice and counsel, or a combination thereof during the development of the Mini-School Program.

### Corporations and Agencies

Atlantic Richfield  
Celanese  
Equitable Life Assurance Society  
Exxon  
First National City Bank  
IBM  
Interpublic Group  
McGraw-Hill  
Mobil Oil  
New York Telephone  
Pfizer  
Port of New York and New Jersey Authority  
Scholastic Magazine  
Touche-Ross  
Union Carbide  
Western Electric

### Foundations

Astor  
Robert Sterling Clark  
Donaldson, Lufkin and Jenrette  
Educational Facilities Laboratories  
Fels  
Ford  
Fund for the City of New York  
Grant  
J.M. Kaplan  
New York Community Trust  
New York  
Noble  
Taconic  
vanAmeringen

### Institutions and Organizations

City University of New York  
Columbia Law School  
Economic Development Council  
New York University  
Parsons School of Design  
Public Education Association  
United Federation of Teachers

### Consultants

Fox and Fox Associates  
Louis Harris Associates  
Open Channel Television  
Optimum Computer Systems  
Weber Associates

# Table of Contents

Foreword	i
Acknowledgements	iii
CHAPTER ONE — Education, Reform, and the Management Alternative	1
CHAPTER TWO — Alternatives: Education for a "New" Clientele	9
CHAPTER THREE — Mini-Schools: The Haaren Model	23
CHAPTER FOUR, PART ONE — Mini-Schools: The Haaren Experience	35
PART TWO — Focus on:	73
Developing Human Resources	
Planning, Organization, and Management	
The Physical Environment	
Business Involvement	
Streetworkers	
CHAPTER FIVE — Educational Alternatives: The Future	97
HANDBOOK, PART ONE: Restructuring Your School	105
Step One: Educating Yourself	
Step Two: Analyzing the Data	
Step Three: Reaching a Decision	
Step Four: Getting the Green Light	

Step Five: Initiating the Planning Process  
Step Six: Setting Your Objectives  
Step Seven: The Written Plan  
Step Eight: Adopting the Plan  
Step Nine: Implementing the Plan  
Step Ten: Developing Human Resources  
Step Eleven: Institutionalizing Change  
Step Twelve: Evaluating the Results

HANDBOOK, PART TWO: Dealing with the Nitty-Gritty

129

Preparing Your Budgets  
Identifying Your Resources  
Developing Curriculum  
Identifying Your Clientele  
Developing Student Programs  
Scheduling the Mini-School  
Planning the Environment  
Deploying Your Staff  
Using Outside Resources  
The Counseling Function  
Promoting Interaction and Growth  
The Information Factor  
The Diplomacy of Change



## Foreword

The crisis of performance and credibility in the public schools, particularly those in the inner cities, has engendered literally hundreds of experiments across the nation in what has been termed "alternative education." Some of these experiments are being conducted entirely outside the existing school system; others operate within the system. All involve departures from the traditional patterns of teaching and administration and place greater stress on meeting the needs of individual pupils and teachers.

Notable among them is the Mini-School Project, a cooperative effort of the New York Urban Coalition and the New York City Board of Education. The three-year-old project involves the division of Haaren High School, located on Manhattan's West Side, into twelve so-called "mini-schools," enrolling an average of only 150 students and each with its own, distinctive academic program and teaching staff. While there are scores of attempts at the development of mini-schools under way in various cities, including some 50 in New York alone, the Haaren project is believed to be the only one involving conversion of an entire existing high school to the mini-school format.

While proponents repeatedly claim that alternative education projects hold great promise for improvement in attitudes, attendance, dropout rates, and learning disabilities, little has been offered that would serve to document such accomplishments. Accordingly, the New York Urban Coalition has concluded that the fullest possible documentation of the Haaren experiment is an absolute essential.

This book represents part of the overall attempt to fill that need. It outlines the shortcomings of the existing system that gave rise to the alternative-school movement, traces the history of the early alternative schools, citing their successes, shortcomings, and failures, and discusses the reasoning behind the Haaren project. From there, it proceeds to a full and frank analysis of the Haaren experience, identifying both the successes and shortcomings of the project, then takes a look at the future, not only of the Mini-School Project but of alternative education and school renewal in general and the potential impact of the alternative-school movement on established school systems, particularly in the inner cities.

Finally, the concluding chapter is presented as a guide or "cook book" for educators and community groups interested in launching their own alternative-school programs based on the mini-school approach and the processes involved. It offers a step-by-step road map, covering such areas as planning, organization, management, financing, administration, staffing, day-to-day operation, involvement of the business community, and facilities planning and acquisition.

More formal documentation of the Haaren experience, in the form of continuous academic and attendance records and evaluations by outside consultants, has been underway since 1970. Meanwhile, it is hoped that this book, aimed at a broad, national audience, will be of direct assistance to others across the nation struggling to find new and better ways to provide education for young people not now well served by traditional school systems.

The New York Urban Coalition

# Acknowledgements

As the serious reader will appreciate, the story of alternative schools in general and the Haaren High School Mini-School Project in particular, is highly complex. Without the help of scores of interested and involved people, preparation of this book would have been impossible.

Obviously, it would not have happened without the initiative of the New York Urban Coalition, its former president, Dr. Eugene S. Callender, and the staff of its Education Program. I am particularly indebted to Louis McCagg, Education Program Director, and Lynn Gray, who headed the Haaren project, not only for their comprehensive knowledge of the subject matter but for the guidance they provided in reaching other sources of information.

At the same time, this book could have been neither comprehensive nor candid in its approach without the cooperation of Principal Bernard V. Deutchman and the majority of the administration, faculty, and staff at Haaren High School. Despite reservations on the part of some over the preparation of this volume, all who were contacted by the author proved willing to talk about their experiences and, in candid fashion, offer their own evaluation of the project and its successes and shortcomings.

Also appreciated was the willingness on the part of high officials at the New York City Board of Education to take valuable time to share their viewpoints with the author. Similarly, representatives of the corporate world were unstinting in their willingness to share their views of school reform projects and corporate involvement therein. And I must express my appreciation to a long list of outside consultants, university personnel, and experts in a variety of fields who, in one way or another, had much to contribute.

Obviously, space is inadequate here to name all the names. To correct that omission, a full list of the appropriate members of the Urban Coalition staff, the Haaren High School staff, and all others interviewed in preparation for this volume is offered as an appendix.

Meanwhile, my very special thanks go to Rosie Carvin, who as the person who keeps things going at the Urban Coalition's Education Program, was extremely helpful at all stages of this project. And my admiration to Linda Cremona, Nancy Cruz, Elaine Fontaine, and Valerie Helms at the Coalition, who were able to translate my less-than-accurate typing and scribbled-in corrections into a neat and readable manuscript.

JJM

## Chapter 1

# Education, Reform, and the Management Alternative

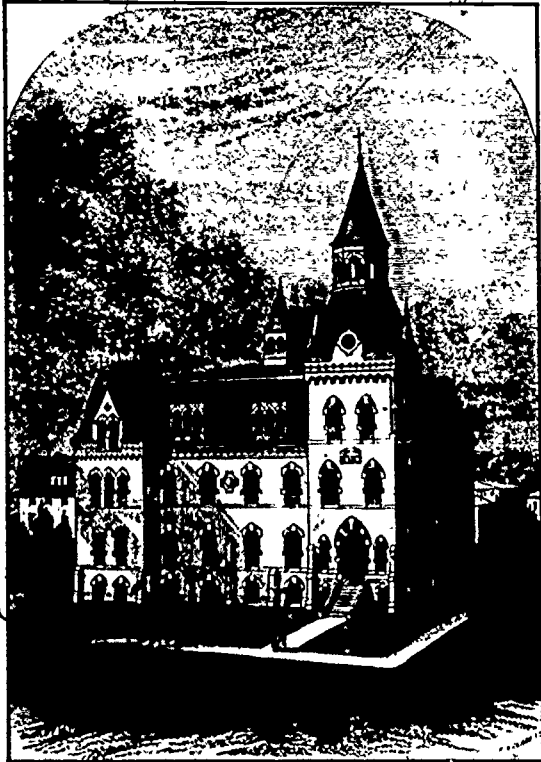

MODERN HIGH SCHOOL

The mission of public education, to put it succinctly, is to provide the student with the knowledge, skills, and motivation that will enable him to function and to compete as an equal in modern society. That the schools, and particularly those in the nation's inner cities, are failing in that mission, is all too apparent and documented in the evidence and statistics issued by the school systems themselves. These failures have been thoroughly exposed by such critics as Jonathan Kozol, Nat Hentoff, and others. Indeed, the crisis in urban education has generated a literature of its own. Beyond the landmark exposés of the late 1960s, at least 20 major books devoted to the crisis and/or proposals for its solution were published in 1973 alone.

Some of the critics—notably Frederick Mosteller and Daniel P. Moynihan in their book, *On Equality of Educational Opportunity*, and Christopher Jencks in *Inequality. A Reassessment of Family and Schooling in America*—suggest that the schools, as now organized, not only are failing to do the job but are incapable of making a real difference.

The schools, as the critics see them, are mindless, unhappy places, staffed by teachers who are unable to communicate with their students and unfeeling in dealing with, or, more appropriately, failing to deal with their problems. Overseeing the schools is a bureaucracy characterized by inertia and a concern more

with budgets, buildings and security than with the welfare and achievement of young people and their teachers. And, if these conditions can be said to exist throughout most of the school system, they are even more critical in the inner city. There, the schools are victims of municipal budget crises, rapid shifts in the ethnic and socio-economic character of populations, teachers who feel trapped by the system, and a host of related problems. The result is that teachers, with severely limited resources, are attempting to deal with students whose life style, problems, and language they are unable to comprehend. And they must cope in conditions where overcrowding, disorder, hunger, disease, crime—all the symptoms of urban poverty—are all too prevalent.

The end result is a performance record for the inner-city schools that is little short of abysmal: students who cannot read or calculate, massive truancy (reaching as high as 70 percent in some New York high schools), soaring dropout rates, and a system that relegates most students who manage to graduate to a second-class educational certification—in some cases, a general rather than an academic diploma.

Perhaps the best summation of the situation was offered as long ago as 1967 by Dr. Kenneth B. Clark at a conference on urban education organized by this writer. Dr. Clark,

professor of psychology at City College of the City University of New York and member of the New York State Board of Regents, called city school systems "protected public monopolies with only minimal competition for private and parochial schools."

The result, he added, is an inefficient system that "destroys rather than develops positive human potentialities, consumes funds without demonstrating effective returns, (and) insists that its standards of performance should not or cannot be judged by those who must pay the cost. . . ."

The picture, of course, is not uniformly grim, there are exceptions to the rule. There have been schools, programs within schools, or efforts by individual teachers that have produced favorable results. And the system has not been totally unresponsive. New York City, for example, for years has allocated additional funding to deal with such problems as reading retardation, pupils whose native tongue is not English, school breakfasts and lunches, and the like. And, in its controversial school decentralization plan, New York has handed a degree of control over the schools to locally elected neighborhood school boards.

But the more dramatic and probably more significant response—the establishment of "alternatives" to the traditional schools at the high school level—came from outside the school system. The earliest of the alternative

schools came as a form of rebellion and were operated and financed totally outside the system. They emerged out of a conviction that the system was not serving poverty and minority group youth and that the education being offered was irrelevant to their needs.

As will be seen in the following chapter, most of the early alternative schools or "street academies," as they were known in New York, did not survive. Their failure was due largely to the fact that they had no linkage to the school system and therefore no means of certifying the achievement, if any, of their students. In addition, most ran into problems of financing, management, and, because of a lack of documented performance, credibility.

But their existence led to later projects in which alternative education programs were developed with formal links to existing high schools. That process, discussed later in detail, led ultimately to the conversion of Haaren High School into twelve mini-schools. And the Haaren experience, more than three years old at this writing, suggests that there may, after all, be a way to make the inner-city school responsive and functional.

The key to the solution is the realization that the schools must rethink their objectives with a view to changing to meet the needs of a changed—and changing—clientele.

The schools, in other words, must shed their traditional role, characterized by Lynn Gray of the Urban Coalition as a holding action "designed to keep young people out of the job market as long as possible. Delay rather than involvement is the name of the game. And we play it well."<sup>2</sup>

Gray argues for a new conception of the school as a generator of social profit rather than, as it now is characterized, a non-profit organization. Under that new conception, he sees the schools forging closer links with the community and with the changing realities of the world around it. He would have the principal spend at least one day a week away from the school working in such areas as social maintenance, corporate management, government agencies, and in schools serving other socio-economic and ethnic populations. Formal, working links would be developed with other community institutions for the development of cooperative programs. And he argues for the development of "more interdisciplinary, activity-based, learning environments within the school. The boxes (classrooms) have to be more creatively used and interconnected. More attention has to be paid to group interaction and the development of learning communities."

Alvin Toffler, author of the best-selling book *Future Shock*, argues for even closer links with the community. In an interview with this writer in 1972, Toffler claimed that

society, "through the interminable prolongation of adolescence, robs children of the sense of being needed. . . .

"In reality, the message to the child from most families and most schools is. 'You are not needed.' This is the most debilitating, crippling, painful message any human being can receive. We need to create a system that does not look on students as parasites—as they are frequently regarded by conservatives—or as investments—as they are viewed by liberals and the majority of educators. I prefer to look on students as neither parasites nor investments but as resources for the community."

Accordingly, Toffler would move education into the community, assigning teams of students to work with community leaders and with their teachers on a wide range of local problems—pollution, noise, traffic, crime—now neglected because of a "lack of resources." Conversely, he would tap the talents of community residents to give students, on a one-to-one basis, a working knowledge of his or her vocation or profession.

Toffler does not suggest that the school will disappear, only that it will be radically altered. That view is shared by Edward J. Meade, Jr., program officer in charge of public education for the Ford Foundation. Meade, in a pamphlet entitled *Models for Reforming Education in the City*,

holds that the schools are needed for stability "in the sense of giving children structured and expanding experiences in learning keyed to the realities of the times."

But he argues that there is no reason to lock in the means—"the places, procedures, process, programs, or people"—by which the stability is provided. "Injustice is done by holding onto traditions and practices that deny children full opportunities to learn. School people, their citizen supporters, and friendly critics and goads, need to evaluate continuously every facet of school life, from curriculum to schedules to teacher training. Is the way schools are doing things now in keeping with work and life styles outside the school? In an era of liberation, in what ways does our educational system perpetuate mindless, regimented action? What practices reflect sheer anachronisms?"

The message, whether from Clark, Gray, Toffler or Meade or, for that matter, many another observer, is clear. The urban schools as now organized and operated are failing in their basic mission of educating their clientele to function effectively in a rapidly changing world. The schools, therefore, must undergo radical change. And once initiated, change will be a never-ending process.

And, if the schools are to undergo radical change, it is



obvious that they will have to develop the ability to change. This means that, as the Haaren experience has indicated, the schools will have to develop an accurate picture of their new objectives, new organizational structures, and new managerial techniques to implement them, and new capabilities in the personnel who must carry them out.

Put another way, the schools will be forced to adopt modern methods of planning, management, and personnel development, but tailor them to an educational rather than an industrial environment. In industry, the process has come to be known as management by objectives or M.B.O. Under that approach, the manager and his subordinates agree on realistic objectives and on the standards by which progress is to be measured. The process is a continuous one, lending itself to adjustment to meet changing conditions.

Perhaps the best explanation for the failure of the schools to respond to changing needs is the fact that, as understood by industry, "planning" and "management" have been terms and functions that are alien to the educational profession. Indeed, the schools seem to be operating on a blueprint drawn up decades ago when life, and urban life in particular, was simpler and traditional educational objectives for the most part went unchallenged. Even today, it is not until a school is on the verge of total deterioration or

total disruption that educational administrators tend to perceive a need for change. And, when the need is perceived, few have the vaguest notion of how to bring about the needed changes. Nor can they expect miracles to save the day. "The first law of serendipity," according to Dr. Ewald B. Nyquist, New York State Education Commissioner, is that "in order to discover something you must be looking for something."

The fact of the matter is that little or no machinery exists in today's schools to permit the administration and staff to sit down and re-examine their objectives, assess their accomplishments and failures, set new objectives, and reorganize and regroup to meet them.

In New York City, for example, the high schools have cabinets or consultative councils which meet periodically, presumably to set policy for school operations. But such meetings generally are limited to 45 minutes—a standard school period—once a week and to generalized discussion of a day-to-day problem or problems rather than to a conscious and organized problem-solving effort.

As far as can be determined, never in the traditional schools is there an effort to develop a semester-long or year-long plan setting forth goals, in terms of academic achievement, attendance, dropout rates, and the overall

environment for learning, and suggested target dates for their accomplishment.

Part of the problem lies in the fact that school principals receive no formal training in planning and management, do not perceive the need, and do not perceive themselves as planners or managers. Nor do they feel that teachers or, for that matter, lower-level administrators have the capabilities to participate in the decision-making process. Teachers, on the other hand, tend to feel that the administration is not interested in their views and would not listen to them if they were included in the planning process. The result is a serious impasse. If teachers are not participants, the planning effort is unlikely to succeed.

In the short run, therefore, there is need to change the attitudes and skills at all levels of the organizational ladder. The principal must be persuaded that those who do not plan have their "planning" happen to them by the course of events. He must be convinced that there are other and better ways to operate than by crisis management. Once that attitudinal change is accomplished and a formal planning process set in motion, it then becomes a matter of educating the staff to the fact that there are rewards in the process of thinking out problems on a long-term basis rather than attempting to meet the crises on a day-to-day basis.

For the long term, it seems apparent that there needs to be some fresh thinking about the ways in which school administrators are trained. The management skills needed in an operation of the size of a typical urban high school simply are not provided in university courses for educational administrators or by in-service training. What probably will be needed, according to Lynn Gray, Haaren Project director for the New York Urban Coalition, is two years of solid management training for anyone seeking promotion to the post of assistant principal or higher levels.

"If you have a \$5-million business (roughly a year's operating cost for a large city high school)," added Louis McCagg, director of the Coalition's Mini-School Project, "it seems neither efficient nor logical to allow it to be run by people who have not been trained to some degree as professional managers, particularly where young people are involved."

Provided with administrators who are both professional educators and professional managers, it is possible, according to Lynn Gray, that the typical high school administrative hierarchy could be cut by as much as 60 per cent without a loss of educational efficiency.

Teachers, on the other hand, should not require as much formal training in management techniques. Once planning

has been institutionalized in the school, faculty involvement in and exposure to the process should serve effectively as on-the-job training.

Teachers will need a set of new capabilities to equip them for their new roles in the changing school program. School reform is premised on the redesign of the total learning environment—the school organization, the curriculum, teaching styles and techniques, and, where appropriate, the physical arrangement of the school. To provide the teacher with the ability and skills required to help develop and implement that new environment, new programs of training and support will be required.

As an example, the Haaren mini-school project included development of a professional services center to assist teachers in such efforts as redesigning curriculums for the various mini-schools, developing audio-visual materials, and improving reading programs. In addition, Haaren teachers are given half-time off for a semester at a time to develop new curriculums for their mini-schools. In addition to producing new learning patterns and materials, the process can serve as an effective in-service training device. Three-week training sessions for teachers were held during two successive summers and a series of afternoon training sessions, including lunch, were held during the

school year at the offices of four New York-based corporations.

Among other things, the training sessions were aimed at helping the teachers understand their new role in the mini-school environment, that they were no longer just the deliverers of information in a particular discipline but managers of the students' total learning process.

The ultimate message is that educational reform, whether it be on the mini-school or another pattern, requires a comprehensive effort, one that touches on all aspects of school life. Piecemeal innovations—computer-based instruction, a new mathematics curriculum, work-study programs, to offer some examples—are unlikely to succeed if tried in isolation.

And that comprehensive effort involves three key elements—planning, management and organization, and human development. Some may argue that application of industrial management techniques will have a dehumanizing effect in the schools. The answer can only be that there is little that is "humanizing" about today's massive and impersonal high school. And, if management techniques are what it takes to provide an effective and relevant educational experience for disadvantaged youth, can we afford not to adopt them?

"Any successful school, including the most traditional," says Louis McCagg, "has had some planning go into it somewhere along the line. Effective programs just don't happen without careful thought."

<sup>1</sup> Morisseau, James J., "Inner City School House. Too Many Slum Buildings, Now Time for Revewal." *Christian Science Monitor*, October 7, 1967, Page 11.

- See also, Toffler, Alvin, ed., *The Schoolhouse in the City*, Frederick A. Praeger, Inc., New York 1968.

<sup>2</sup> Gray, Lynn, "The School is Not a Non-Profit Organization." *Mini-School News*, Vol. 3; No. 9, March/April 1974. New York Urban Coalition. )

<sup>3</sup> Morisseau, James, J., "A Conversation With Alvin Toffler," *National Elementary Principal*, Vol. 52, No. 4, January 1973.

<sup>4</sup> Meade, Edward J., Jr., *Models for Reforming Education in the City*, A Ford Foundation Reprint. 1974.

## Chapter 2

# Alternatives: Education for a "New" Clientele



The phenomena of reform, innovation, and experimentation probably are as old as education itself. Indeed, it can be argued that the earliest attempts at formal instruction were, in themselves, innovations. And more recent history offers the examples of the so-called progressive education movement of the 1920s and '30s, the post-Sputnik emphasis on science and foreign languages, and the introduction of such innovations as educational television, team teaching, non-graded instruction, and independent study. Even then, some would argue that, with the exception of educational television, none of these experiments was really new, that they merely were re-inventions of methods and procedures that had been employed in the past.

Given that background, what, if anything, sets the new alternative school movement apart from earlier educational reforms and innovations? After all, there always have been "alternatives" in education. Students, and their parents, provided they had the wherewithal, had the choice between the public school system (and between different public school systems if they could afford to move), parochial schools, and private day or residential schools. But, to a large and growing segment of the American population, these offered no real options, since economic and other barriers made all but their local free public schools inaccessible.

Just as the schools failed their immigrant clienteles earlier in the nation's history, it became apparent in the late 1950's and early 1960s that the modern public school system was not effectively serving its "captive" constituency, particularly youngsters from minority and poverty backgrounds. Dropout rates soared, as did truancy, behavior problems, drug use, and crime. And it was recognition of the problem among concerned individuals and groups, most outside the educational establishment, that generated the movement toward alternative forms of education. Accordingly, it can be argued that, unlike earlier reforms, alternative schools are the product of a demand—expressed by dropping out and other forms of alienation—on the part of a significant segment of the school's clientele rather than on the part of the educational or political leadership.

Mario D. Fantini, former program officer of The Ford Foundation's Division of Education and Research, argued back in 1968 that earlier educational reforms, particularly those in the post-Sputnik era, "strengthened the *status quo*, enabling the system to serve better those who it has always served best. (Early reforms such as team teaching and educational television usually were introduced in "strong" school systems in the affluent suburbs. The assumption by foundations and other supporters was that,

once proven successful there, the reforms would automatically be adopted throughout the system. The assumptions proved to be unfounded. Ed.) The heart of the present crisis in public education is the realization that the system has failed a major segment of the school population."<sup>1</sup>

The failure was not new, according to Fantini. What was new was a public awareness growing out of "official cognizance of poverty amidst affluence" and a new tendency among the nonwhite fourth of society's underclass to assert its civil rights and demand a full share in political and economic opportunity." But, Fantini argued, preoccupation with the disadvantaged should not preclude recognition that the total system was "incapable of addressing the challenge of providing excellent education for a diverse student population. Consequently, the mission of fundamental educational reform is not for the poor alone but for all."

Put another way, there is a considerable body of dissatisfaction with the traditional public schools, not only among the obvious clientele in the ghettos but among some in the affluent suburbs, a fact that has been reflected in the establishment of free schools and other alternative forms in some of those suburbs. The extent of the demand for new educational options is difficult to evaluate. In a recent

book, Fantini suggests that some 60 per cent of Americans, including "millions of parents and students," find "our present pattern of public education attractive." On the other hand, he estimates that 28 per cent of the people are dissatisfied and need "to have their right to quality education protected." Otherwise, he suggests, there will be "a search for satisfaction" that will "inevitably disturb the climate in the schools for everyone."

Another, perhaps more solid indicator may be found in the sheer numbers of alternative or optional schools or programs that have sprung up in recent years across the nation. The National Consortium for Options in Public Education in 1972 published a directory of alternative public schools. It identified 464 such schools in 35 different states but found, significantly, that 75 per cent of them were located in eight states—California, Washington, New York, Massachusetts, Pennsylvania, Minnesota, Illinois, and Missouri—with the first three states accounting for more than 40 per cent of the total.

The directory cannot be said to represent the total picture in alternative education. It excludes free schools and other options functioning outside the system and certain non-traditional programs operating within the system. Among the latter are "special-function" schools, usually for disruptive pupils, such as New York's system of "600 schools,"

and "open enrollment" programs, such as that in East Lansing, Michigan, where pupils are allowed to attend any school in the community, regardless of geographic proximity.

At the same time, the directory underscores a critical fact: there is great diversity in the alternative-school movement. It includes a poll of 276 schools across the nation, indicating that 76 per cent were at the secondary-school level, 19 per cent at the elementary level, and 2 per cent in K-12 (kindergarten through twelfth grade) schools. More importantly, the directory pointed out that there is "no single model or group of models" that would cover the diversity of the schools in responding to the poll. But it concluded that the majority fell into seven broad categories or combinations thereof. They included "open schools" based on the British pattern; "schools without walls," such as Philadelphia's Parkway School, where learning activities are dispersed throughout the community; "learning centers," where learning resources for all community students are concentrated in one location such as educational parks, "magnet" schools, and career education centers, "continuation schools," such as drop-out centers, pregnancy maternity centers, evening and adult high schools, and street academies, "multi-cultural centers," including bilingual schools, "free schools," emphasizing greater

freedom for students and teachers, and "schools-within-schools," including mini-schools programs on the Haaren High School pattern and satellite programs like that at Wingate Prep in Brooklyn or Harambee Prep in Manhattan.

That very diversity suggests that the alternative movement suffers from a serious problem in semantics. The term "alternative" does not fit since, by strict definition, it implies the availability of only two options, when, in actual policy and practice, the ultimate objective of most recent school reforms is to offer a variety of options. Similarly, the term "mini-schools" means different things to different educators and reformers and better description is yet to be found. "Options" may come closer as a catchall definition for the movement. But, given the movement's diversity, the Fantini definition, "public schools of choice," seems at the same time comfortably vague and yet descriptive.

As vague as its semantics, are the actual origins of the alternative school movement. The Indiana directory-builders found programs dating back to 1964. But it may be remembered that, as early as the late 1950s and early '60s, parents protesting school conditions in Harlem took their children out of classes and set up their own educational programs in storefronts and church basements. The

protests and the "alternative" schools were relatively shortlived. But they well may have set a precedent for what was to follow.

What can be established is the fact that the movement in New York got its start in late 1965 with the establishment of the first of that city's street academies at the Church of the Master in Harlem. The street academy actually was an outgrowth of an experimental summer program for New York City youth conducted by three churches, among them the Church of the Master, then headed by the Reverend Eugene S. Callender.

The program was initiated by Harold Oostdyk, a young and energetic member of Young Life, a national Protestant youth organization. Oostdyk, a native of Clifton, New Jersey, had dropped out of New York University in 1954 to work with young people in nearby New Jersey communities. Three years later he moved into Manhattan's Lower East Side and began to work with school dropouts in an attempt to persuade them to return to school. The effort proved unproductive at first, formal school programs or job training offered no lures to the dropouts. But the prospect of a college education did and Oostdyk and his colleagues from Young Life, some of whom shared their apartments with homeless clients, embarked on their own educational program. By 1962, a number of the dropouts



were ready for a more formal, pre-college program. That year, two were enrolled in Newark Preparatory School, a private institution headed by Arthur Garson, and two more were enrolled the following year. Eventually, five of the Newark Prep enrollees went on to college and did well.

Meanwhile, Oostdyk began to consider Harlem and its large numbers of school dropouts as a natural focal point for his activities. Through Edward Fiske, now religious editor of the *New York Times*, he met Callender, who had been contemplating a more active role in the community for his church. Oostdyk, on the other hand, needed a black base such as offered by the church if he was to successfully introduce his program in Harlem. The result was a partnership that produced the summer program and ultimately New York's first street academy.

The summer effort, particularly at the Church of the Master, produced two significant developments. The first was the realization that, if ghetto youth were to be helped by such programs, there was need for a new type of community worker—individuals capable of communicating with even the most disruptive of their clientele and capable of helping them find solutions to their problems, whether they involved economics, health, family instability, employment, housing, or the law-enforcement system. The result was the emergence of what has come to be

known as the "streetworker," a major component of a number of today's alternative school programs.

At the same time, it became clear that the streetworker component by itself was not enough. There was an educational element, and a very serious one, in the problems of the youth enrolled in the summer program. Many, if not most, had "voted with their feet," and dropped out of a school system that, by their perceptions, failed to meet their needs or, worse, treated them as unwanted, disruptive elements in the student population. Many of those who still were in school had records of frequent truancy and/or disruptive behavior. And these were problems with which the existing system seemed unable or unwilling to cope.

That conclusion prompted the thought on the part of Reverend Callender, Oostdyk, and others that it might be possible to create a new and more responsive educational environment and more relevant programs that would help such students discover their own potential and gain an interest in pursuing their education. They proceeded to design a model for their new educational environment and programs. Subsequently, in December 1965, New York's first street academy opened in the basement of the Church of the Master. The educational program was run by Dr. Susie O. "Doc" Bryant, formerly educational consultant for Haryou-Act, a federally funded Harlem youth agency,

while Oostdyk and others from Young Life served as streetworkers. By early 1966, between 200 and 300 youths were being served by the new program.

Early operations were financed out of the church's limited resources, by a grant of \$212,000 from the Lilly Endowment, and by a number of smaller grants. Later, a grant of \$106,000 was obtained from the Office of Economic Opportunity to help finance the program for the summer of 1966. But, later that year, it became apparent that the program was in fiscal difficulty. Twenty-three street academy graduates now were enrolled at Newark Prep, where the program had run up a debt of \$21,000, and an expected additional infusion of OEO funds had not materialized.

Dr. Callender, meanwhile, had been named executive director of the New York Urban League and, shortly thereafter, appointed Oostdyk as education director to run the program, which by then had grown to include three storefront academies in addition to the Church of the Master operation.

To meet the crisis, Dr. Callender turned to The Ford Foundation for an emergency injection of funds. The Foundation, while not impressed with the program's financial record, was impressed with its objectives and methods

and with Dr. Callender's contention that 70 per cent of the 16-to-21-year-old age group in Harlem was college potential. After a tour of the storefronts by Foundation President McGeorge Bundy, a grant of \$147,000 was approved in September 1966.

With the infusion of these new funds, the program continued to grow, not only in size but in structural sophistication. To the street academies, which concentrated on streetwork and basic remedial education programs, were added two "academies of transition," which offered more formal programs in the traditional high school subjects but tailored to the students' interests and experience. From there, successful graduates were sent to Newark Prep to complete their college entrance requirements.

By late 1966, there were six storefronts in operation, the two academies of transition, and a total of 40 streetworkers in the program. Ford was impressed enough with this performance that, while stressing that this would be a final grant, it put up another \$550,000 to keep the program afloat. But the grant carried with it another and significant stipulation as set forth in the grant letter:

"If this project is to have its fullest impact, it must be linked up in some way with existing institutions in educa-

tion. Otherwise the academies would be serving too few people in relation to the total needs of Harlem, Bedford-Stuyvesant, and similar areas."

The first street academies, meanwhile, served as a prototype or model for those that were to follow. A key element in the model was smallness. enrollments in the individual academies ranged between 15 and 30, the premise being that limited enrollments would promote intimacy and interaction between students and teachers and avoid the institutional impersonality of a large school. The second major component was the inclusion of streetworkers as a critical part of the schools' operations. Both of these components remain as key factors in many of today's alternative school projects.

Still another critical component—the involvement of business and industry—came later in the academies' history. Beginning in 1968 with the McGraw Hill Publishing Company, as many as 14 major corporations, including such giants as First National City Bank, Esso (now Exxon), New York Telephone, Union Carbide, IBM, and Celanese, were persuaded to lend their support, in both money and talent, to the program, helping it to reduce its dependence on Ford and other foundation support. Early in the game, business involvement generally was characterized by gifts of equipment and direct subsidies for the budgets of individual ac-

demies. Later on, as will be seen in succeeding chapters, the involvement tended to shift toward the use of corporate talent to help alternative schools improve their management and operations.

The program expanded to the point that, by January 1969, there were 14 corporate sponsored academies in operation, ten in Manhattan, two in the Bronx, and two in Brooklyn. At that point, Dr. Callender and Oostdyk, acting on their own and the Ford Foundation's convictions, moved to establish linkages with the established school system. By early 1968, five academies in Harlem had been closed and their streetworkers moved into four high schools—Benjamin Franklin in East Harlem, Charles Evans Hughes on 18th Street near Ninth Avenue, Haaren at 58th Street and Tenth Avenue, and Seward Park on the Lower East Side.

Within a year after their first involvement, the sponsoring corporations grew disenchanted with the street academies. The business participants recognized a number of common—and special—characteristics in the academies: their small size, a clientele, predominantly if not exclusively Black and Puerto Rican, most in need of their special brand of education, experimental remedial programs, young, enthusiastic, and dedicated teachers, and the streetworker component. In fact, streetworkers were considered so essential that their relationships with stu-

dents often took precedence over classwork.

On the other hand, the corporate supporters saw gray areas. Dr. Norman C. Willard, former vice president for personnel at First National City Bank and an active corporate participant in the program, feels that, initially, the academies represented "a form of rebellion" and were decidedly anti-establishment in nature. As such, Willard believes, they had a tendency to become a system unto themselves but a system that "lacked specific objectives."

That lack, according to Willard, led to "a terrible looseness," not only in educational goals but in management and in the handling of funds. Perhaps more critical, there was no machinery by which academy students could earn credit or some other form of certification for their studies, since there was no link with the established school system. And, as Willard and others have argued, while the academies' general objectives by and large were highly admirable, little or no attempt was made to evaluate their performance, to determine to what extent those objectives were being met.

What followed, according to Willard, was the withdrawal, one by one, of the corporate sponsors of the program. His own organization attempted to resolve the problem by establishing a link between a FNCB academy and Ben-

jamin Franklin High School. While it no longer has bank support, the academy still is in existence:

Ultimately, most of the original street academies went out of business or, in one way or another, were absorbed into the regular school system. But those that were absorbed retain many of the characteristics—particularly smallness, special curriculums, and deeply involved teaching staffs—that made the original academy concept seem so promising. Those that disappeared attest to a harsh reality: even with the loftiest of intentions, reform in education is an extremely difficult and risky endeavor. Reviewing their history, it could be argued that greater expertise, particularly in the area of management, might have saved the academies. But that would be hindsight at best. The important fact is that the street academies broke the ice. They set a pattern and established a momentum that has resulted in widespread adoption, particularly in New York City, of the mini-school concept.

The street academy experience also points to a conclusion, reached by more and more observers in recent years, that alternative schools cannot survive indefinitely without public funding. Perhaps the classical example is Harlem Prep, founded in 1966 as a tuition-free school for drop-outs. The school originally was intended to serve the same function as Newark Prep, preparing graduates of the street

academies and academies of transition for college entrance. Organized and staffed with the help of Manhattanville College, a Catholic school for women in Purchase, New York, Harlem Prep opened in an armory at 142nd Street and Harlem River Drive and the following year moved into an imaginatively remodelled supermarket in Central Harlem, in effect becoming that area's first high school.

The Harlem Prep board of directors, which was independent of the street academy program, selected Edward Carpenter, who had been a guidance counselor in the New York City Schools, as headmaster. Under Carpenter, the school tended to drift away from the street academies and to place stress on more traditional programs leading to college entrance for Harlem youth. And, over the six years of its existence, it succeeded in that objective, placing a total of 637 of its graduates in college, many of them in the nation's leading universities.

Initially, Harlem Prep was supported by the foundations, which saw it as a proving ground, by such corporations as Exxon, and by many private donors. But foundations shy away from indefinite funding of experiments, on the premise that successful projects should become self-supporting. Corporate givers tend to adopt a similar attitude. As a result, the schools' funding had declined in

recent years. Appeals for direct support from private donors in the Harlem community failed to reverse the trend and, by late 1973, financial difficulties had forced enrollments down from a peak of 500 to 190 students, many of whom were to graduate in January 1974.

Ultimately, the school was forced to appeal to the New York City Board of Education and, as of February 1, 1974, Harlem Prep became part of the city school system. However, the school will remain in its present site and will retain its headmaster, staff, and curriculum. All of this, according to city schools Chancellor Irving Anker, "in the framework of public education."

A sidelight to that development was the reaction of Albert Shanker, president of the United Federation of Teachers, one that illustrates one of the problems in the replication of alternative models in the system. Shanker, in his regular weekly column run as an advertisement on the New York Times Sunday education page, suggested that data on the school's performance were inadequate and that its claims of success were "unwarranted . . . and constitute an unfair attack on the public schools." He concluded that, "if standards had been maintained rather than ignored, Harlem Prep might have done a better job." By "standards," the UFT president referred to that fact that the school "was not required to maintain legally required

standards in its employment of faculty members or in matters of curriculum." Without debating the validity of the "legally required standards" referred to, the Shanker position suggests that, despite a UFT policy favoring reform, many teachers are and probably will continue to be highly sensitive about the issue of school reform and may, when they feel their job security or working conditions are threatened, actively resist specific reforms.

Meanwhile, in early 1968, a new organization appeared on the New York scene, one that would play a major role in the evolution of alternative schools in the city. The New York Urban Coalition was founded in an attempt to bring private-sector resources to bear on a wide range of urban problems.

The Coalition's first president, Saul Wallen, died unexpectedly in August 1969 and was succeeded, on August 28, 1969, by Dr. Callender, who for the preceding year and a half had served as an executive of New York City's Housing and Development Administration.

In an early action, the Coalition decided to provide support for the academies and for the streetworker concept and was instrumental in obtaining the corporate involvement described earlier. The Coalition's task force on education spent some four months in developing films and

brochures and conducting informational meetings to "sell" the concept. The result was about \$650,000 in corporate financial input into the street academy idea.

But, according to Louis McCagg, then task force staff director and now head of the Coalition's Education Project, evaluation, follow-up and technical assistance on the part of the corporations, and organization of the street academies "all were woefully short as we look back on it."

In part as a result of these problems, the street academy program began to fragment and progress was "less than adequate." McCagg maintains that the germ of the idea was "extremely good and still is." But the problems had to do with the selection and training of academy staffs, their organization and discipline, and the question of evaluation. As outlined earlier, these problems caused the sponsoring corporations gradually to phase out of the program.

An exception was the McGraw-Hill Street Academy. Its sponsor, the McGraw-Hill Publishing Company, from its first approach to the Urban League in 1968, insisted that the academy be established with a link to an existing high school and that it be located in McGraw-Hill's "neighborhood," the west side of mid-Manhattan.

Morrie Helitzer, then corporate vice president for public affairs for the McGraw-Hill Publishing Company, feamed

up with Lynn Gray, who had been involved in a successful program at one of the earlier academies. Both felt the move would get at the heart of the matter—the school system itself. For it was clear that the academies not only were not having a real effect on their students but were having no impact on the system. School principals and others in the educational leadership were not visiting the academies and generally regarded them simply as a place to send dropouts and troublemakers—the “dumping-ground syndrome,” as it has come to be called.

Accordingly, Helitzer and Gray approached Jacob Zack, then assistant superintendent in charge of the city's high schools to determine whether an appropriate school could be found that would be willing to link up with the new street academy. Zack encouraged the idea and suggested Haaren High School, which suited McGraw-Hill's neighborhood requirement. Bernard V. Deutchman, Haaren's principal, proved amenable to the idea and the McGraw-Hill Street Academy opened in February 1968 in a former automotive repair shop at West 61st Street and 11th Avenue, with Gray as its director. Deutchman agreed to provide one regular teacher for the academy staff and to list the academy students on Haaren's attendance rolls provided they attended regularly. The arrangement, according to Helitzer, provided the basis for a joint venture between a street academy and a public school.

Toward the middle of the first year of academy operation, Helitzer and Gray opened new discussions with Deutchman, Dr. Elliot Shapiro, then district superintendent, and Zack to find ways to move the academy physically into the Haaren building. All, including Deutchman, were receptive to the idea. But, after checking his class schedules and room utilization patterns, Deutchman reported that adequate space could not be found.

However, the Haaren principal suggested that space might be available at Charles Evans Hughes High School, two miles downtown in Manhattan's Chelsea district. George Shirkey, then acting principal at Hughes, was willing to listen and a study was undertaken to determine whether a self-contained wing could be made available to the academy. As it turned out, a wing was out of the question. But, in a compromise move, the academy took over an area of the Hughes building about the size of three classrooms.

The arrangement proved less than ideal. Space limitations held the initial enrollment to 68. The academy area could not be physically separated from the rest of the building and, for that among other reasons, proved inadequate. Some among the Hughes faculty resented the loss of space and regarded what by then had been named Harambee Prep as a foreign element and threat. And, as had

happened in the original street academies, the dumping-ground syndrome began to show itself.

Four months later, in January 1970, the situation was resolved by moving Harambee into a nearby annex of Hughes, where, five years later, it occupies the entire top floor of what had been a commercial building. (Other floors of the building house Hughes' College-Bound program.) The new location meant that Harambee could increase its enrollments—drawn from the McGraw-Hill Academy, Haaren, and Hughes—to more than 100 and that it had a territory or " turf" with which students and staff alike could identify. Gray, who had moved from the McGraw-Hill Academy to be director of the new school, had a staff of four teachers, three of them paid by the Board of Education, and one streetworker. Gray was forced to raise funds to pay the fourth teacher and the streetworker, a situation that hampered his efforts to run the school.

Deutchman at the same time had forged links with the existing Morgan Guaranty Academy on the Lower East Side, meaning that Haaren students at the time had the option of attending two alternative schools. Morgan Guaranty eventually became Lower East Side Prep and ultimately, in September 1973, was totally absorbed by the school system. The McGraw-Hill Academy, incidentally,

continued operation in its repair-shop location for two years after Harambee's opening before going out of business.

September 1970 also saw the opening of a parallel experiment, called Wingate Prep, in Brooklyn. Wingate, with an initial enrollment of 40 students, was housed for the first three years of its operation in the ground floor of a converted warehouse located more than a mile from George Wingate High School, the parent organization. The building later was taken over by Medgar Evers Community College and was to have been converted to accommodate both college and Wingate Prep facilities. However, drastic delays in the renovation work forced the prep school to move to new quarters in a former convent, which it now shares with the Wingate Mini-School, a newer alternative and also linked to the parent school.

The Harambee and Wingate projects offered solid evidence that semi-autonomous mini-schools, employing the components of smallness, streetworkers, and support from the business community, could function within the established school system and produce results. At Wingate, for example, a professional evaluation team found that the staff had produced "a unique climate . . . particularly for the urban high school . . . relaxed, friendly, and warm, and as open and informal a school setting as



could be imagined."

The evaluators, Fox and Fox Associates, rated the quality of instruction as high—"well above average for the high schools they knew"—and gave positive ratings to teacher characteristics and performance, and the school's innovative Black Science course, which coordinates instruction in history, English, biology, and mathematics.

On the other hand, they complained that the relaxed attitude in the school extended to record-keeping, resulting in long-delayed entering of grades. And they noted a "high level" of noise and distraction, a reliance on teacher-centered instructional styles despite small classes, a lack of remedial reading teachers, an unattractive physical setting, and a lack of student participation in the running of the school.

From their inception, the Harambee and Wingate projects represented a cooperative effort by the Board of Education, the United Federation of Teachers, parent and community groups (such as the Friends of Wingate), the business community (the Pfizer Corporation at Wingate Prep), and, as the catalytic agent, the Education Program of the New York Urban Coalition. By early 1971, it appeared that these experimental efforts to provide a more effective education for students "turned off" by the traditional

system had paid off. It seemed time to take the next step, to determine whether the satellite mini-school idea could be extended to that of the "mini-school complex," where the model would be employed to convert an entire school into a complex of sub-schools, each with small enrollments, business support, and the streetworker component.

In fact, the Urban Coalition staff, in cooperation with Board of Education officials already had begun a search for an appropriate high school in which to try the mini-school complex idea when what must be regarded as a history-making letter arrived at the desk of Dr. Eugene Callender, president of the Coalition. The letter was from Bernard V. Deutchman, principal of Haaren High School, and read in part:

"Haaren High School is a school deteriorating before our eyes. We have a 60 per cent drop-out rate, a 70 per cent truancy rate, and tremendous distrust between the various groups which comprise the school. We are desperate.

"As Principal, I have decided that we must undertake a radical change to survive. If Haaren cannot be changed, if steps cannot now be taken to make it a true place of learning, then I predict it will collapse.

"To initiate the process of change, we have examined a number of experiments in the city to find what might be relevant for us and help provide the guidelines we need.

“We believe the mini-school approach, where teachers and students have programmatic freedom and autonomy, is the direction we ought to take.”

The date was April 30, 1971. the stage was set for the Haaren experiment.

<sup>1</sup> Fantini, Mario D., *Alternatives for Urban School Reform*, A Ford Foundation Reprint, Vol. 38, No. 1, 1968.

<sup>2</sup> Fantini, Mario D., *Public Schools of Choice: A Plan for the Reform of American Education*. New York, Simon and Schuster. 1973.

<sup>3</sup> Educational Alternatives Project, School of Education, Room 328, Indiana University, Bloomington, Indiana 47401.

## Chapter 3



### Mini-Schools: The Haaren Model

Principal Deutchman's appeal to the Urban Coalition led ultimately to a decision to "turn Haaren High School around" and, beginning in September 1971, convert the 2,500-student school into 14 mini-schools, each with an average of 150 students, its own teaching staff, a director or coordinator, and a guidance counselor, and each with its own, distinctive academic or career "theme."

The decision was a momentous one. Never before had there been an attempt to take an entire existing high school and reorganize it, virtually from one semester to the next, into an entirely different structure offering totally new academic programs. To complicate matters, Haaren, as suggested in Deutchman's letter, was a deeply troubled school. Only two years earlier, it had been the scene of serious student rioting. School morale was virtually nonexistent. There was little or no sense of community. Alienation rather than communication was the predominant characteristic of human relationships—particularly staff-student relationships—in the school. It was a school, as Deutchman put it, on the verge of collapse.

Obviously, conversion of the school into a mini-school complex would involve far more than the simple replication of earlier mini-school experiments. The satellite mini-

schools, for example, generally were staffed with volunteer teachers dedicated to alternative programs; Haaren's reforms would have to be implemented by an existing staff, many of whom were not convinced the reforms were desirable. Similarly, a new organizational structure and new programs would have to be accommodated in an existing and, by current educational standards, obsolete physical plant. And, unlike the satellite mini-schools, Haaren would not be in a position to pick and choose its student clientele. It would take all comers and many if not the majority of them would be educationally disadvantaged. And, it would have to deal with these problems with no special support from the Board of Education.

All involved—the school administration and staff, their superiors in the Board of Education hierarchy, the Urban Coalition staff, business representatives, and outside consultants—faced a formidable task. The potential for mistakes and, for that matter, ultimate collapse of the experiment, was enormous. Obviously, effective planning and careful implementation were essential if the project was to succeed.

The challenge, then, was to build on the experiences not only of the Urban Coalition but of the groups that sponsored earlier alternative programs in the city. The successes of the earlier projects—such as the phenomenon

of smallness and the streetworker component—had to be incorporated. But their failures, particularly in accountability and management, had to be avoided. Perhaps most important if it was to be fully successful, the Haaren project would have to do what the earlier projects could not, make an impact on the system. To do so, Haaren would have to develop a successful model or process after which other schools in the system could pattern their own efforts at reform.

Or, as summarized in an unpublished Urban Coalition document on the Haaren concept:

"The best of what had been learned in out-of-system projects had to be incorporated into the system and become what the system itself wanted."

The challenge was responded to in a series of planning sessions during the late spring and summer of 1971, involving Haaren's administration, staff and students, the Urban Coalition, and the United Federation of Teachers. Out of that planning effort came a series of decisions about the organizational patterns and academic programs that would be in effect when Haaren reopened the following September. Those decisions, taken together, form what has come to be known as "the five-component model" for Haaren's mini-school complex.

The first and most critical component was the mini-school structure. Haaren was to be divided into a series of semi-autonomous units—initially 14 in number—that would operate within the total school structure. Enrollments in each mini-school would be small—ranging from 75 to 500 and averaging at about 150. Each would have its own coordinator and guidance counselor and, to the extent possible, its own permanent teaching staff. Facilities for each mini-school—including classroom, lounge, and office space—were to be provided in separate and identifiable areas of the school and each mini-school was to have its own academic, career, or other programmatic theme.

The mini-school structure was designed to take advantage of the success of the earlier projects in utilizing small school units to engender intimacy and interaction between students and staff, a quality seldom found in schools like Haaren when organized around traditional subject-area lines. Teachers in each mini-school were to have the opportunity to coordinate their programs to achieve common learning objectives for their students. And they would be involved in the development of new curriculums built around their mini-school's programmatic theme. Finally, the theme and a definable physical location or "turf" were expected to engender a sense of belonging and community among the students in each mini-school.

It must be stressed, however, that the concept envisioned something more than a loose collection of small-school units. As the name implies, the mini-school complex was to be an interlocking network of mini-schools whose programs would be coordinated by the school's central administration. Such coordination would make it possible, for example, for a student to transfer without academic or other difficulties from one mini-school to another when such a move was called for by changes in his interests or achievement level. And it would make it possible to enjoy the advantages of mini-school smallness without sacrificing the strengths of a large educational organization.

The central administration, for example, would continue to provide such services as the library; central record-keeping; quality control; bulk purchasing of goods, equipment, and materials; professional development programs, and the like. Similarly, it would insure the maintenance of breadth and flexibility in the curriculum as well as a broad range of professional specialization in the teaching staff.

On the other hand, the mini-school complex offered an opportunity to provide far more variety in programs than possible in a traditional school organization. The possibilities can be illustrated by a brief description of the themes and objectives of the 14 mini-schools opened at

Haaren in September 1971. It might be noted beforehand that some of the new mini-schools—notably College Bound and English as a Second Language—were developed out of programs already in operation at Haaren. Others were entirely new. In all cases, themes, objectives, and curriculums, were developed by teacher planning teams with, as will be seen in the following chapter, varying degrees of clarity and thoroughness. The first Haaren mini-schools, in thumbnail sketch, were as follows:

**Co-op Mobil**—A Blend of the Cooperative Work Study Program (in which students spent alternative weeks in school and on the job), and the Mobil Oil Corporation Training Course, (a joint venture of the corporation and Haaren's Industrial Arts Department). The objectives, develop marketable skills and prepare students for entry-level jobs in service stations, correlate industrial training with academic studies, and, develop self-confidence through work experience.

**English as a Second Language**—Built on an existing state-funded program, ESL employs an interdisciplinary approach to meet the special needs of students from non-English speaking backgrounds. ESL's clientele ranges from recent immigrants with no knowledge of English, some illiterate in their native tongues, to students who require upgrading in their English skills to function effectively in

other Haaren programs.

**Correlated Curriculum**—Assists students in surveying and choosing careers in such occupations as electronics, transportation, and drafting. The program is designed to build self-confidence and a positive self-image in its students and to build their skills through second, third, and fourth-year programs aimed at career specialization.

**STEP-TUM**—Another hybrid, this mini-school combines two work related programs. One, The School to Employment Program (STEP), is designed for students on the verge of dropping out and permits them to attend school for a half day and spend the other half at a job provided by the Board of Education. The second, the Training for Upward Mobility program, is designed to instill in tenth graders an understanding of the academic skills required to perform in a variety of jobs. Again, students split their day between school and jobs.

**Aerospace**—Designed to articulate with junior high school programs, Aerospace Mini-School utilizes an interdisciplinary approach in providing prevocational training in the aerospace field for entering ninth-year students.

**Aviation**—Similar to Aerospace but aimed at entering sophomores, Aviation Mini-School employs a correlated-curriculum approach to the study of aviation-related topics.

**Automotive**—Designed as an introductory experience for entering tenth-year students interested in the automotive field and to capitalize on that interest in developing basic academic skills.

**Pre-Tech**—A two-year course open to juniors or seniors and designed for students interested in pursuing career-oriented programs at a two-year community college. Career areas include construction, chemical, electrical, mechanical, and electro-mechanical technology, or design and drafting. Academic and industrial art studies are correlated.

**Executive Business**—A program designed to meet the needs of students planning to enter the business field as executive trainees, salesmen, or independent entrepreneurs. Computer training is offered.

**Creative Arts**—Helps students develop an awareness and sensitivity to the visual arts. An interdisciplinary approach is employed not only to stimulate an appreciation for the arts but to develop artistic talent in individuals.

**Urban Affairs**—Offers students the opportunity to study their urban community through a variety of in- and out-of-school programs. Two days a week are spent outside the school, in an effort to create a "school-without walls," in which as much learning as possible occurs outside the school building.

**Operation Return**—Designed to improve attendance among frequent truants, re-orient them to the school community, and assist them in recognizing the value of an educational experience. Flexible and individualized programs are employed to help the student develop specific vocational and academic goals.

**College Bound**—Largest of the mini-schools, College Bound is aimed at providing college-entry qualifications for students having the requisite academic skills and potential. It is the most traditional, in both curriculum and teaching methods, of the Haaren mini-schools.

**Special Education**—Provides special programs for retarded or otherwise educationally handicapped students.

Let the reader be misled by the use of the present tense, the foregoing descriptions were adapted from statements of theme and objectives developed at the outset of the Haaren project. As will be seen later on, a number of the mini-schools described no longer exist. Indeed, one or two, lacking clarity of objectives, student interest, or both, never got off the ground. That development underlines a basic characteristic of the project, to be underscored later in this chapter. The Haaren concept is not a rigid blueprint but a dynamic plan; a framework within which significant change has occurred and probably will continue to occur.

The Haaren concept's second component—the streetworker—like the structural component is an adaptation from the original street academy practices. At Haaren, however, the streetworker assumed a somewhat different role, one that is more closely integrated into the operations of the school.

To the early streetworkers, the workplace was the street. Their job was to find the dropout or drug addict, develop rapport with him, then attempt by persuasion, cajolery, and sometimes outright bullying, to lure him to the street academies and, thereby, to a start on the road back into the educational mainstream. In short, the first streetworkers were recruiters who "mined" the streets, pool halls, and playgrounds for salvageable talent, working day and night in the process.

The streetworker, in the Haaren scheme of things, still spends some time in the street, but it is restricted by his in-school responsibilities. He is less a recruiter and more a link of liaison between the students and the faculty, the administration, service agencies, and, where necessary, the home. His function, rather than recruiting those who already have dropped out, is to encourage the potential dropout to stay in school and, to the extent possible, provide whatever assistance is required to achieve that objective.

Under the Haaren concept, the streetworker has become a regular employee of the Board of Education and an integral part of the school staff. As such, he performs a variety of in-school functions that tend to keep him in the building the greater part of his working day or week. Among those functions are supervision of student lounges, contacting the parents of truants or seriously disruptive students by phone or mail, and preparation of reports of his daily activities.

On the other hand, the Haaren streetworker continues to live up to his title, spending part of his time in the neighborhood urging cutters to go to their classes or even, where circumstances warrant, visiting the parents of students with serious problems.

By the same token, it is his job to know which people at which agencies, both public and private, can help students and their families with problems, whether they involve the law, health or mental health, housing, employment, or drugs, and to make appropriate contacts and referrals. He often fills a critical need among minority group students—the presence of a strong male image from his racial or ethnic background with which the student can relate. And Haaren streetworkers make themselves available to the students outside school hours and will accept student phone calls at home at any time.



Finally, in their liaison role, the streetworkers perform a new and critical function in a school like Haaren. They in effect act as interpreters between students and staff, helping teachers not only to understand the language their students speak, but their "alien" attitudes and life styles. And, in some cases, streetworkers have worked side-by-side with the teacher in the classroom, helping the teacher communicate with the students and generate interest in the course material. In fact, there have been claims that the best-attended classes at Haaren are those in which a streetworker is involved.

Conversion of a school such as Haaren into a mini-school complex poses the need to develop new, interdisciplinary educational communities, new teaching methods to convey the new curriculum to students in a meaningful manner. That need has generated Component Three in the Haaren Model — the Teacher-Service Center. Known as the Professional Services Center (PSC) at Haaren, this new support unit is designed to provide the potential for continuous teacher development to meet the changing needs of the mini-schools as well as the machinery for development of new curriculum and materials.

The PSC, headed by an assistant principal and supported by outside consultants, acts as a resource center and workplace for teachers who have been released from part of

their teaching load to develop curriculum. At the same time, it offers a conduit through which the staff can tap outside resources and expertise in both curriculum development and teaching methods. It is a place where experimental programs, teaching materials, and techniques can be designed, tested in practice, evaluated, then, if warranted, incorporated into the school program. And, theoretically at least, the PSC provides a forum where staff members can gather to exchange ideas about mini-school operations, programs, and methods and capitalize on the successes of their colleagues.

The center, which focuses on program analysis, training and staff development, professional resources, and curriculum development, is designed to support and help develop the mini-schools rather than simply to assist individual teachers or projects in isolation. Teacher success is seen as a function of the success of the appropriate mini-school and teacher development is regarded as an integral part of mini-school development.

Another critical component of the Haaren concept was that of business involvement. Initially, it was represented by a business loanee office, staffed by two executives on loan from major corporations. Their role was to identify possible partnerships between corporations and the various mini schools and to make the necessary arrangements.

In addition, they were to help find other ways in which corporate resources in talent, materials and equipment might be brought to bear on the school's problems. But, as will be seen later, it soon became apparent that a new role for the loanees was called for, one that would help the school to more effectively plan, organize, and manage itself to meet changing needs. The new business involvement, at Haaren and elsewhere, had to help the school system "get at the root causes of its failures."

Fifth and last of the original Haaren concept components is the "full-service school." Essentially an effort to deal with the full range of problems affecting the education and welfare of inner-city youth, the full-service idea represented an attempt to make Haaren a conduit through which delivery of all essential social services to its students could be insured.

Behind the concept was the realization that traditional assumptions about the responsibility for the delivery of different services—that the family took care of housing, value formation, and such questions as religion and sexual attitudes, that schools develop basic skills, organizational discipline, and preparation for work, and that public and private agencies handle health, legal, housing and other social problems—tend to break down in the inner city environment.

Accordingly, the full-service school was to concern itself with the total welfare of its students, undertaking a thorough audit of services provided in the school, of services provided through the school by outside agencies, of services provided totally outside the school, and of student perceptions of their needs and how services might best be delivered. The effort then would be to take steps to insure that appropriate delivery mechanisms were developed and that they functioned effectively.

As will be seen later, the full-service school is the only one of the five Haaren components that has not been implemented. That failure can be attributed to a number of causes. But probably the most critical is the fact that existing municipal agencies are not well organized to deliver services to a clientele such as Haaren's and that reform of these agencies is beyond the capability of Haaren and its supporters or, for that matter, of the school system. The full-service school, however, remains as an ideal to be pursued, a concept that, sometime in the future, may prove feasible.

The Haaren concept, as suggested earlier, is far from a static blueprint that would freeze Haaren into a new but equally rigid mold. Hard, practical experience over the three years of the experiment has brought changes, some of them major, in the thinking not only of the school's

administration and staff, but of the Urban Coalition staff, and others involved in the project. Most critical has been a realization, on the part of all concerned, that reforms of the sort involved in the Haaren project require a major new emphasis on *rational* development through planning, organization and management, and the upgrading of human resources.

These new requirements cannot be considered as new components in the Haaren concept, since they impinge on all five of the original components. But, as events have demonstrated, they are critical to the success of the Haaren project and, for that matter, to the success of any radical reform in the schools.

In Haaren's case, according to Cynl Tyson, management consultant to the project, neither the Urban Coalition staff nor the Haaren administration at the outset "really understood what planning meant." They did not realize that desires and general statements of objectives do not constitute an operational plan and that, without an operational plan and concomitant changes in organization, management, and individual skills, the project was unlikely to succeed.

Tyson argues that there are two basic approaches to the process of changing an institution. The first is to "cut off

the top" of the organization and put a new manager in his place, as happened when Robert McNamara took over and revamped the Pentagon. The second is to attempt to institute changes from within.

The first approach clearly was unworkable at Haaren and, for that matter, would not work in most school situations where jobs are protected by tenure and by union contracts. The second, accordingly, offered the only real alternative at Haaren. But it meant that the very people who perceived themselves most threatened by change would have to function as the change agents.

Accordingly, it was essential that the staff be involved in a process under which the general goals of the Haaren project were translated into specific objectives, responsibility assigned for their achievement within specific time limits, and machinery (accountability systems) established to insure that the schedule was met.

The procedures for carrying out such a planning process are described in detail in the Handbook section of this book. Meanwhile, at Haaren the process resulted in creation of a number of critical new elements in the school structure. Among them, as will be seen in Chapter Four, was establishment of a new instrument to carry out the continuing process of planning for change. Known as the

Haaren Planning Group, the new unit includes the principal, two assistant principals, a guidance counselor, a mini-school coordinator, a streetworker, and the chairman of the school's chapter of the United Federation of Teachers.

The planning group provides the machinery for the orderly introduction of proposals for change, whether from within the school or from outside organizations like the Urban Coalition, and for revision and ultimate acceptance or rejection.

Significantly, one member of the planning group is the assistant principal in charge of the school's Management Development Office (MDO), another new Haaren entity devoted to dealing with overall management problems in the school. The office develops budgets, conducts systems studies in such areas as security, staff roles and responsibilities, student records, and inventories of school resources.

The MDO also provides the vehicle for a new and more effective business involvement at Haaren. The school's business loanees, who initially had their own office, ultimately were moved into the MDO, where they worked with the management director rather than on their own.

The stress was on cooperation, a team approach, in which the business loanee's knowledge of organization and management was employed as a resource. In the process, their image as "outsiders" interfering in school affairs was replaced by a sense that they had become an integral and supportive element in the school structure. The loanees helped not only in systems studies but in establishing a mechanism for the definition of goals, the identification of problems, the setting of priorities, and plans for implementation.

In addition, they helped identify problems that lend themselves to solution through the application of business skills or knowledge or by other types of corporate assistance. And they helped coordinate business efforts in the school to insure maximum return from such inputs.

In a related development, the school's management structure was reorganized to give the assistant principals, who earlier had functioned as subject-matter chairmen, direct line control over the mini-schools. The move clarified the lines of authority in the school, reduced the number of units reporting directly to the principal, simplified the decision-making process, and, most desirable in the eyes of management specialists, meant that authority was delegated to a lower level of the managerial hierarchy.

As will be seen in the following chapter, Haaren's new planning, management, and development machinery is not yet operating to its full potential. But it is, in place and, in varying degrees, functioning. In effect, Haaren now is organized to deal with the fact that the process of change initiated by the mini-school project, will be a continuous one and that the school must plan, organize, and manage itself accordingly.

## Chapter 4 (Part 1)

## Mini-Schools: The Haaren Experience



Serious as they were, the problems at Haaren High School were not the only factor in Bernard V. Deutchman's decision to convert Haaren into a mini-school complex and to turn to the New York Urban Coalition for help. Nor was it a spur-of-the-moment decision. In fact, Deutchman had been discussing the possibilities with the Coalition's Lynn Gray for more than a month before writing his letter of April 30th to Dr. Callender.

Furthermore, Haaren's principal four years earlier had been exposed to the early street academies and the concept behind them. Sometime in late 1966 or early 1967, Deutchman had been introduced to Harold Oostdyk and Herbie Miller, key figures in the street academies, and asked to tour a number of the storefront operations. "His reactions were mixed. The academies, he concluded, were "doing a good job and overcoming many difficulties." But they had physical problems with their storefront locations, and lacked trained staff and supervisory personnel. The Board of Education, in Deutchman's view, "ought to be able to do a better job of coping with the same types" (high school dropouts). And he felt that the academies were performing a "disservice" by neglecting an important body of students—potential dropouts who still were in school.

Deutchman took no immediate action on his new convictions but

his understanding of the academy concept undoubtedly contributed to his receptivity when, later in 1967, it was proposed that the new McGraw-Hill Street Academy be linked to Haaren. That linkage, which saw Haaren students enroll in the academy and at least one Haaren faculty member assigned to its staff, gave Deutchman three years' experience with mini-school-type operations. And it is significant that, when a proposal to move the academy into the Haaren building fell through, Deutchman was instrumental in the negotiations that led to its move to Charles Evans Hughes High School and the subsequent establishment of Harambee Prep.

Meanwhile, in a development that could not help but whet the Haaren principal's appetite for change, his school was wracked by a series of riots in 1969. The uprisings, presumably sparked by students who had been involved in the 1968 riots at Columbia University, included mass student walkouts, rock-throwing incidents, confrontations with the police, and a number of arrests. At the end of it all, Deutchman said recently, "I was the (school system's) expert on student riots."

In any event, it was not a stab in the dark on Deutchman's part when, in March 1971, he approached Lynn Gray with the suggestion that the Urban Coalition assist him in restructuring Haaren. He knew enough about mini-schools

and the concept behind them to feel that the approach held promise for his school. The problem was in finding ways to implement it.

There followed a series of almost daily meetings between Deutchman and Haaren staff members on one side and the Coalition staff on the other, seeking ways to cooperate in setting up a mini-school complex. On several occasions, Haaren teachers were brought in to brief Coalition staff personnel on their experiences and problems.

Out of these meetings came Deutchman's letter to Dr. Callender, outlining Haaren's problems in dramatic terms and formally requesting the Coalition's assistance. Negotiations continued while Deutchman took the mini-school idea back to his staff for approval. The concept was presented to the school's cabinet, which then included his assistant principals and a representative of the school's chapter of the United Federation of Teachers. The cabinet suggested that approval be left up to the faculty.

Initially, as Deutchman remembers it, the faculty response to the concept was one of "it sounds reasonable, but you haven't given us enough of the details." Accordingly, a planning committee was established to formulate more specific proposals both for faculty approval and for inclusion in a formal presentation to the Chancellor

Harvey B. Scribner. The committee met daily in Deutchman's office to work out the proposed new school structure and develop the proposal. Scribner, meanwhile, had been informed of developments and, in a letter dated May 13th and addressed to the Coalition's High School Project, expressed interest in the idea.

A detailed plan was presented to Haaren's faculty in late May and, in a formal vote on May 26th, the project was approved by a margin of 61 per cent to 39 per cent for presentation to Scribner, provided that he made no substantial changes in the plan. The following day, Deutchman, members of his staff and student body, Coalition personnel, and business representatives met with Scribner in the board room of the McGraw-Hill Corporation to formally present the Haaren project.

Scribner's response was favorable. He endorsed the plan but said that he would have to study the financial implications, which included a request for 16 additional staff positions. Ultimately, the Chancellor gave final approval, but with the proviso that no additional Board of Education expenditures would be involved, including nearly all of the new positions. Deutchman took the revised plan back to his faculty, which gave it overwhelming approval in a voice vote. Later, the plan was put to a vote by the student body, whose response, intriguingly enough, was

almost identical to that of the faculty—60 per cent in favor and 40 per cent opposed.

The final go-ahead for the project came on July 13th in a letter signed by Scribner and all five members of the Board of Education. The letter committed the Board to provide \$104,000 in State Urban Education funds to finance a summer training program for the Haaren staff and an additional \$15,000 in state funds for a basic skills laboratory. In addition, alteration of the Haaren building to accommodate the new program was promised, with completion scheduled by the opening of classes in September.

Financing of the streetworker component of the project was another matter. Scribner earlier had indicated that the Board was not in a position to pick up streetworkers' salaries, at least for the first year of the experiment. The Coalition then turned to the Ford Foundation, which committed \$250,000 (later reduced to \$200,000) to finance the streetworker program for the first year.

The Board, in its July 13th letter, acknowledged that the Ford contribution was "in anticipation of the time when the Board of Education will share increasing responsibility for support of the streetworker program" and committed itself to "make every effort to finance the streetworker



component along with the Urban Coalition partnership in 1972-73 and ensuing years."

In addition to funding the streetworkers, the Coalition was committed to support the project through the involvement of its own professional staff, the use of outside consultants, and, through its auspices, the introduction of business loanees and the development of partnerships with business organizations. Haaren, for its part, was committed to the implementation of the plan and to the structural reorganization and redeployment of personnel that was entailed.

### "INSTANT" RESTRUCTURING

Time became a critical factor. The agreement, calling for implementation of the plan by September, meant that Haaren was to be completely "turned around" with less than three months of planning time at the disposal of its staff and its outside partners. The objectives and programmatic themes of the new mini-schools had to be developed and refined. Training programs had to be designed and implemented to insure that at least a cadre of teachers and staff were prepared for their new duties and to provide basic training for the streetworkers, who had been newly recruited by the Urban Coalition. And new curriculums, designed around an interdisciplinary

approach, had to be developed for each of the new mini-schools.

The result was that the restructuring of Haaren High School amounted to a crash program. The hastily organized teacher training program offers a case in point. The program, a three-week workshop attended by assistant principals, guidance counselors, mini school coordinators, 40 per cent of the teaching staff, all 15 streetworkers, and 41 student volunteers, was conducted in 15 five-hour sessions running from August 9 through August 27. Its objectives were to orient the staff to the philosophy and objectives of the mini-schools and the features of the individual mini-schools; to familiarize teachers with the origins, economic status, and living conditions of mini-school students; to familiarize the staff with the characteristics of the "feeder" junior high schools from which Haaren received its entering students, and to develop curriculum and instructional materials for the new mini-schools.

An evaluation of the workshop, conducted by the Syracuse educational consulting firm of Richard Ford Associates, Inc., indicated that little, if anything, was accomplished. The workshop's objectives, the evaluators complained, were "very general and ambiguous" and "very little planning was done to see that these objectives were met." The participants, the report complained, were

confused over the accomplishments expected of them. Morning group sessions failed to provide direction and guidance, bored the teachers, led them to feel that workshop leaders were confused, and "probably had a negative effect on the workshop." Curriculum development sessions, the evaluators added, became "rap sessions" for teachers and failed to effectively involve students and streetworkers.

On the positive side, the report concluded that it was possible that some "team-building and group formation" occurred, but noted that this was not a stated objective of the workshop. In summary, the evaluators concluded that "concrete accomplishments were slight. . . . Whether mini-schools succeed or fail in Haaren High School, it should be realized that over \$100,000 have been spent in a disorganized and quite worthless three weeks."

That experience, and others to be described later, generated speculation and debate that continues to this day over the timing of the project. Interviews with teachers, administrators, Coalition personnel, and outside observers, produced a considerable body of opinion holding that at least a year should have been devoted to planning and the training and orientation of personnel prior to implementation of the plan.

On the other hand, there is a pragmatic side to the question. Few among those interviewed denied that more time for planning would have been desirable. But to many in key positions both at Haaren and in the Coalition, it was a case of "now or never." Their view is typified by that of Principal Deutchman, who conceded that the crash approach produced "quite an upheaval" at Haaren and that "real educational innovative programs ought to take time." But, he added, "if we hadn't done it then, we never would."

That view was supported by David J. Fox, whose educational consulting firm has conducted two evaluations of the Haaren project. The problem, according to Fox, is that there is "never enough lead time" for the planning and implementation of educational experiments. He cited the "classic" example of New York City's "More Effective Schools" (MES) program, a system-wide attempt at providing better instruction for disadvantaged pupils. MES, he pointed out, was agreed upon in July and implemented in September. But the problem Fox added is not limited to New York. The nation, he said, "is not willing to spend the dollars on education required to do anything properly. . . . it's a national tradition."

It should be noted that a separate training program for

streetworkers, conducted prior to and following the teacher training workshop, apparently produced more positive results. The 15 streetworkers had been selected by a Haaren committee from a list of candidates recruited by Calvin Ramsey of the Urban Coalition. Some of the 15 had relevant experience in such areas as job or narcotics counseling. All were regarded as having the ability to relate to young people. And all showed leadership qualities. But all required training in the specific skills required in their new assignments.

In an initial week-long session, August 2 through 6, the streetworkers were briefed on the streetworker concept, on the role of the Urban Coalition in sponsoring alternative models, the specifics of the Haaren project, and the skills, tasks, and responsibilities involved in their new assignments. Finally, they were given a familiarization course in the resources—primarily municipal and private agency services—available to them in providing help to students. The course included field visits to representative agencies.

The following three weeks were spent at the teacher-training workshop, after which there was a concluding week-long session for streetworkers only, during which outsiders were called in to discuss and analyze the functions they would perform in working with students. The

discussions ranged from group counseling techniques employed in dealing with students' family or emotional problems to specific approaches to dealing with drug or health-related problems. In addition, time was devoted to analysis of the political attitudes or concepts of black and Puerto Rican students.

While there was no outside evaluation of the streetworker training, the trainees' reaction to the program, set forth in narrative reports and responses to a questionnaire, indicated an *esprit de corps* had been developed and that the streetworkers clearly understood their new roles and functions. The only weakness in the program was indicated by the fact that only half felt that it had provided them with adequate skills for the counseling of students.

### YEAR ONE: A SHAKY START

As scheduled, Haaren High School opened the 1971-72 school year as a mini-school complex. All told, there were 14 mini schools, each with a coordinator and staffed largely by teachers who had elected that mini-school during planning meetings the preceding spring. Each had its own programmatic theme and presumably a new curriculum tailored to that theme (see Chapter Three) and to an interdisciplinary approach. And each had the services of at least one streetworker.

The business-partnership component was activated in an office staffed by two loanees. Richard Kameron of the Exxon Corporation and Al Simon of the Port of New York Authority. The business representatives' office attempted to identify ways in which business resources—technical, managerial, and material—could be employed to help the mini-school experiment work. Its efforts were focused both on the total school, its management and organization, and on the individual mini-schools, with the objective of creating partnerships between business firms and mini-school programs. Exxon, for example, was brought in to help upgrade the program of the Automotive Mini School. And the office arranged for contributions to Haaren by a total of 16 corporations in the course of the school year. Included were such efforts as a study of the school's attendance and record-keeping operations by the Atlantic Richfield Company and the acquisition, from Exxon, of pocket calculators for the Aerospace and Aviation Mini-Schools.

At the same time, a municipal services delivery office was set up under the direction of Gene McCabe, formerly of the City Human Resources Administration, who had been hired by the Urban Coalition to head the new operation. The office undertook to compile complete data on the structure, programs, and personnel of both municipal and

voluntary service agencies, develop training programs to help streetworkers deal with such agencies, secure cooperation of agency personnel in data compilation, delivery of services, and streetworker training, and secure the assignment of "municipal services coordinators" to Haaren and other target high schools. In part because of the difficulty in overcoming the inertia of the municipal bureaucracy, few of those objectives were realized. McCabe left the job in June 1972 and was not replaced.

In a parallel operation, a law student office staffed by students at the Columbia University School of Law was set up to improve the delivery of legal services to Haaren students. Services included answering student questions about the legal system, referring students and streetworkers to attorneys, and maintaining liaison with Legal Aid attorneys handling student cases.

The law students handled a total of 33 cases, including subway offenses, landlord-tenant problems, student rights cases, drug prosecutions, excessive police action, medical malpractice, bail jumping, and helping a student to start a new business. Accordingly, the project could be described as moderately successful, despite the fact that efforts to inform teachers, streetworkers, and students of its availability were, according to a report on the program, "entirely inadequate," as was the office space provided the law students for meetings with their student clients. But

the project was not continued the following year, primarily because a new Law School dean at Columbia did not find it of interest and because Haaren made no urgent appeal for its continuation.

Meanwhile, planning was under way for the creation of a professional development program that would provide for both teacher training and curriculum development. Out of the planning process came a formal proposal that, in the Spring of 1972, brought a federal grant of \$64,054 under Title II of the Elementary and Secondary Education Act and Title III of the National Defense Education Act.

On the surface, at least, Haaren High School was in operation as a mini-school complex, with all five components—the mini-school structure, streetworker, professional development, business involvement, and municipal services delivery—theoretically in place or under development. But the reality was that the changes essentially were on the surface and that Haaren had a long way to go before its restructuring could be regarded as effective.

The school indeed had been divided into 14 mini-schools, each presumably having its own identity. But the reality was that, with the possible exception of those adapted from earlier programs such as College Bound and English as a Second Language, most lacked any real identity in the

eyes of their students. Nor did most have the new interdisciplinary curriculums envisioned by the plan.

The streetworkers were an obvious, identifiable element in the new setup. But there was confusion on the part of teachers and administrators over the streetworkers' role and little if any communication existed between teachers and streetworkers.

And, in implementing the mini-school concept, Haaren failed to follow the example of Harambee Prep. Rather than create self-contained units with a substantial degree of autonomy, Principal Deutchman opted for an approach he described as "curricular flexibility." The school's assistant principals continued in their roles as chairmen of subject-matter departments rather than assuming a new role as managers of mini-schools.

The result was confusion in the school's managerial structure and in the perception of administrative roles. There was overlapping in the responsibilities of assistant principals and mini-school coordinators, leading to conflict between the two. Attempts on the part of the coordinators to resolve the conflict were rebuffed when Deutchman refused to meet with their council.

The situation was little short of chaotic. Richard Kameros, a first-year business loanee, has calculated that, at the

time, no fewer than 45 administrative personnel reported directly to the principal. The two-layered, overlapping organization, lacking central coordination, clear lines of authority, or definition of roles, created, in Kameros' view, "an organizational nightmare."

The management problems generated an active concern on the part of a review committee made up of executives of a number of Haaren's business partners—First National City Bank, Exxon, McGraw-Hill, and Union Carbide. In an effort to help, the group met repeatedly with Deutchman in the offices of Norman Willard, then a vice president of First National City Bank, reviewing with him possible alternatives in the school's management structure.

The meetings with Deutchman and simultaneous sessions with Board of Education executives continued through the month of December 1971 and culminated in the development of two model plans for Haaren's administrative structure, both aimed at autonomy and a multi-disciplinary approach for the mini-schools.

The alternative models were presented to a special management conference for the Haaren staff held January 28, 1972, at the Holiday Inn, a little more than a block from the school. During the day-long session, staff members were to participate in workshops conducted by

representatives of Exxon, the Urban Training Institute of Young Life, and the Community Council of Greater New York.

The conference got off to a limping start. By 9:00 a.m., a half hour after the scheduled starting time, neither Deutchman nor James Boffman, superintendent of Manhattan high schools, had arrived and only half of the staff was on hand. Finally, at 9:45, Exxon's Harold Roser, the opening speaker, decided to proceed anyway. The workshops followed and, despite the poor beginning and initial teacher skepticism, developed into what Roser and other participants describe as a "stimulating exchange of ideas."

The business representatives hoped that, out of the conference, Deutchman would designate a task force to study the alternative models and workshop recommendations, then develop a new organizational structure for Haaren. But that was not to be. Deutchman, who meanwhile had arrived, took the podium at noon. He thanked the participants and announced that he would let them know which of the two models he would adopt, apparently rejecting the task-force idea out of a concern that, to delegate authority for the decision to a task force, would undermine his authority.

Near bedlam erupted in the meeting room. The business

representatives were particularly incensed. One accused Deutchman of a "betrayal" of the meeting's purposes. And many of the teachers were equally irate, feeling that their efforts during the morning session were rendered a total waste by Deutchman's action. The decision, however, was concurred in by Oscar Dombrow, superintendent of Brooklyn high schools, who was in attendance.

The bitterness among the participants was such that suggestions were made that a second session, scheduled for the following Monday, be dropped as useless. However, discussions over lunch between teachers, Coalition staff members, and business representatives led to a decision to reconvene on Monday and sessions resumed.

Ultimately, Deutchman adopted the first and, according to Roser, less desirable of the two models. It placed each of the assistant principals in charge, both administratively and educationally, of two mini-schools and stripped them of their roles as department chairmen. The rejected model, however, would have provided clearer definitions of the line and staff functions of the assistant principals. The adopted model, according to Roser, was "a step in the right direction but not nearly far enough."

A major weakness lay in the fact that there still were no clear definitions of roles, particularly for the assistant prin-

cipals and mini-school coordinators. The result was overlapping responsibilities and continuing confusion.

Attempts to resolve the problem took a number of forms. A series of meetings, conducted by Donald Kissinger of the Port of New York Authority, were held with the coordinators to help them define and understand their roles. Coordinators and assistant principals, in separate sessions, met with Boffman in an effort to work out their respective roles. But, because overlapping responsibilities had not been eliminated, the situation remained cloudy.

The Urban Coalition, meanwhile, had drafted a three-year master plan for its involvement in the Haaren project. The plan, which for the first time spelled out in detail the five components of the Haaren project, was submitted to Deutchman and Boffman in an effort to impress on them the need for a joint plan of action.

In a series of meetings between Coalition, Haaren, and Board of Education personnel, the master plan was studied and adapted to the thinking of the Haaren administration. At the same time, attention was focused on the apparent failure of the management plan adopted earlier in the year. In addition to formation of a school planning group and a change in the administrative structure, the Coalition suggested that Haaren needed a new administrative posi-

tion, that of management director, responsible for overall management of the school.

The plan was submitted to a joint meeting involving Chancellor Scribner; the top Board of Education officials in Haaren's chain of command; representatives of the Council of Supervisory Associations, the United Federation of Teachers, the Coalition, and Deutchman. Discussion centered on the concept of a management director for Haaren and on a new change in the management structure that would separate the line and staff functions of the assistant principals, thus clarifying the lines of authority and responsibility.

The meeting produced stark evidence of the difficulties in major school reform and of the strains and conflicts that can arise when outside agencies are involved in the process. At one point in the session, Deutchman accused the Coalition staff of "subversion," claiming that he had not been kept informed and had no knowledge of a number of key elements in the plan. He also accused Coalition personnel of promoting programs in the school without his approval.

Deutchman's statement was challenged on the spot by both Boffman and Seelig Lester, then deputy superintendent in charge of instruction and curriculum for the Board. They

reminded the principal that he had been present at a meeting a week earlier during which all plan elements were reviewed. And Louis McCagg, the Coalition's Education Program Director, insisted that his staff consistently had lived up to its commitment to clear all programs with the principal before acting on them.

As a result of the meeting, the master plan was rewritten once again to better define the management director's role and responsibilities and to incorporate several minor changes. Deutchman agreed to schedule a conference in which the plan would be presented to all of Haaren's faculty and at which individual faculty members not interested in working under the plan would be given the opportunity to transfer to other schools. It also was agreed that final role definitions for the assistant principals and mini-school coordinators would be worked out at Haaren and forwarded to the Board of Education for incorporation into the plan.

But, largely because no clear-cut follow-up procedures were established, the plan never was presented to the faculty. Nor were teachers offered the right to transfer. Despite meetings between the Coalition staff, Boffman, and Lester to push for implementation, it was not until mid-July that an agreement was reached on the manage-



ment director's role. Deutchman, however, did call a faculty meeting in June at which he announced creation of the management director's position and the adoption of the new management structure.

The new structure was given final approval at a meeting July 13th between Boffman, Lester, Deutchman, and McCagg. As a result, Deutchman presumably was freed of many day-to-day management responsibilities and given the opportunity to focus his efforts on educational matters. The Coalition's supporting role was reaffirmed and strengthened by giving it a say in policy formulations and a seat on the school's cabinet. The Coalition agreed to recruit the new management director. There was a decision to inform the staff of the new roles of the assistant principals, mini-school coordinators, and the management director by mail. A staff briefing on the three-year plan was postponed until after the reopening of school in September.

Meanwhile, plans for some form of continuing program for teacher training and curriculum development were being pursued. Discussions between the Coalition's Lynn Gray, Haaren Assistant Principal Carroll Jacobs, and Margaret Glotzer, then UFT chapter chairman at Haaren, resulted in a rough plan for a teacher service center and a preliminary proposal for federal aid to support the pro-

gram. Joseph O'Connell, a part-time management consultant to the Haaren Project, was assigned to investigate existing institutional in-service training programs and the development of systems for the introduction of new curriculum into the mini-school programs.

Jacobs and another assistant principal, Edward Blaine, were named by Deutchman to develop a final proposal for federal Title III funds for the program, with the assistance of groups of teachers and students. As it turned out, the school was not organized to write the proposal and, ultimately, the Coalition's Lynn Gray and Yolanda Schuschny joined in the writing effort, along with Roslyn Menzel, who had been assigned by the Coalition in May as participant/observer to the training program. A predecessor to the proposed center—called the curriculum development center—had been established at the start of the spring semester. Headed by Assistant Principal Jacobs, the center was to set objectives for each of the mini-schools, collect course outlines and lesson plans from all teachers, and act as a clearinghouse for new curricular materials. The final Title III proposal was submitted to Albany in June, and, after some negotiation and revision, approved late that month, providing the program with one-year funding totaling \$273,000.

In a parallel effort, work was under way on the redesign of

Haaren's physical plant to accommodate the mini-school complex. Some minor remodeling was carried out the preceding summer to provide lounge and office space for 4 of the original 14 mini-schools. But much more needed to be done if the building was to provide an effective environment for the new complex. Chuck Dickinson, then the Coalition's educational liaison at Haaren, launched the environmental design project at a meeting aimed at enlisting the cooperation of Haaren students. At the same time, he contacted Martin Stein of the architectural firm of Max Urbahn and Associates, who was to become consultant to the project.

Dickinson, working with Stein, attempted to help a number of the mini-schools develop plans for the renovation of their facilities and to encourage other mini-schools to follow suit. The effort ultimately led to development of an "open space" plan that presumably could serve as a model for the physical redesign of many of the mini-schools. Dickinson, meanwhile, contacted Educational Facilities Laboratories (EFL), a Ford Foundation-sponsored agency devoted to improved planning for educational buildings and facilities. EFL expressed interest in the project, lent its advice and, as will be seen, later provided financial support.

The EFL involvement and tours by Haaren staff members of open plan facilities, such as Harlem Prep's converted supermarket, lent impetus to the project and an *ad-hoc* coordinating committee was set up to define the problems and initiate the planning process. Meanwhile, the idea was broached to August Gold, head of the Board of Education's School Planning and Research Division, who gave it his blessing and ultimately, in a letter to Deutchman, committed the board to an investment of up to \$2 million in the remodeling of two mini-schools.

The coordinating committee, involving both staff and students and by now enjoying official status in the school, identified the goals and functions of the mini-schools to be remodelled and, from them, developed general space needs and specific physical requirements. From these, Stein and a team from Max Urbahn Associates developed preliminary sketches that were to form the basis for final plans that would be submitted for Board of Education approval and funding.

## THE SUMMER OF '72

Despite the initial teacher training effort in the summer of 1971 and the subsequent establishment of the curriculum development center, much still needed to be accomplished in the retraining of Haaren's staff to meet their new roles

and responsibilities. The center, which since had been re-named the Professional Services Center, existed largely in structural outline and responsibilities of various parts of the structure still were to be clearly defined.

It was in this context that, in May 1972, planning got under way for a second summer training program. The overall objectives, as stated in the proposal for federal Title III funds, were to give the participants—students, teachers, streetworkers, and administrators at all levels—“competence in skill areas as defined by the roles of participants or their assigned responsibilities.”

In addition, the program was to help participants understand the functions of the new Professional Services Center (PSC) and how they would fit into or be affected by its operation. But, since the PSC structure still was to be clearly defined, the summer program actually could only offer participants a “taste” of the type of training the center was expected to offer when it became fully operational.

As it evolved, the five-week training program was aimed at three basic problem areas: curriculum development, teaching techniques, and management. However, management problems cropped up in planning for all three areas, so that the final plan involved an integrated approach to these problems. The agenda or curriculum offered con-

currently to all participants included training in management skills for the operation of classrooms and mini-schools, the development of student profiles, curriculum planning and development, effective teaching techniques, operation and use of audiovisual equipment, and production of instructional materials.

The stress on management is indicated by the fact that the first week was devoted exclusively to the use of effective management and planning techniques in the Haaren setting. The sessions, held at Ferris Booth Hall on the Columbia University campus, were conducted by Cyril D. Tyson of Optimum Computer Systems, Inc., a management consulting firm. It was the start of a continuing involvement on Tyson's part in the management problems of both Haaren and the Urban Coalition's Education Project. Under Tyson's direction, participant groups delineated the roles and functions at Haaren in relation to overall project objectives. It became clear, during their deliberations, that the planning process at Haaren so far had been lacking specificity as to the activities and procedures needed to meet objectives, that time frames had not been assigned to specific activities and that reporting and review responsibilities had not been spelled out, meaning that accountability would be lacking at any step in the implementation process.

Other sessions were devoted to curriculum planning procedures, presentations of other innovative school programs, student-teacher planning, techniques for teaching reading. Groups were assigned to actual field projects in curriculum development and a management group produced a new set of procedures for student transfers between mini-schools.

The training program proved to be significantly more successful than that of the previous summer. Roslyn Menzel, in a report on the sessions, concluded that the participants had gained valuable new insights, particularly into the importance of teacher planning and the consequences of their failure to plan—dropouts and "crisis management." And she rated as "excellent" the work of some of the curricular planning groups and of the management group.

On the other hand, she concluded that too little time had been devoted to planning for the sessions, primarily because approval of the grant was too late in arriving. The shortage of planning time contributed to the problems, including a shortage of appropriate books and materials and too many last-minute and ill-considered changes in program. Changes in the timing of audiovisual training sessions, for example, meant that some groups enjoyed

highly productive sessions while others missed out on the opportunity to work with the equipment. Another and more serious problem was that some lectures proved to have little relevance for the Haaren participants, primarily because the lecturers had been inadequately briefed on the realities of the Haaren situation, including the school's racial composition. The problem was a product both of inadequate lead time and a lack of awareness of the need for such briefings.

Finally, even though both staff and student participants were paid, attendance was uneven, indicating the need for stricter attendance controls. Overall, Mrs. Menzel concluded that the program had been significantly more worthwhile than those that preceded it but that, given adequate planning time and more sophistication in planning, the sessions could have been more productive.

If the program produced some direct results, it also resulted in a conclusion on Mrs. Menzel's part, of significance for anyone interested in the process of school reform. "Productive relationships develop across traditional barriers when work is shared that relates to common problems, has the support of the administration, and is meant to be used."

## YEAR TWO: A PERIOD OF ADJUSTMENT

By the time Haaren opened its doors to start the 1972-73 school year, three of the original mini-schools—Urban Affairs, Business, and Creative Arts—had disappeared. Their demise, according to Principal Deutchman, resulted in part from the fact that many of their students were those who had indicated no choice of mini-schools the previous year and had been assigned to these three to fill out their enrollments. "The students," Deutchman said, "discovered when they got there (to the three mini-schools) that they were no more interested in school than before, because we weren't providing a program that they had asked for."

He added that, particularly in Urban Affairs, the staff involvement needed "to make that a dynamic and effective mini-school didn't develop to the extent that was necessary." It was, he said, a matter of "creating curricula, creating ideas, creating a viable concept. Then, lacking a sense of direction, the staff itself became disenchanted. So with the combination of teacher disenchantment and student disenchantment, there was no reason to continue that particular program."

The Creative Arts Mini-School, the principal explained, was drawing from other staff sources to keep its arts program going, a situation that "just didn't seem to be justi-

fied." In the case of the Business Mini-School, it was expected that its students eventually would move into cooperative education (in which students work part time). Haaren already had a cooperative education program in the Mobil-Co-op Mini-School. Since the Board of Education would provide only one cooperative-program coordinator, it was decided to merge the two.

Meanwhile, a new mini-school was added to the Haaren complex. Designed for students entering in the ninth grade (some Haaren students enter at that level, others at the tenth-grade level), the new unit came to be known as the SHAFT (for School for Higher Achievement and Fundamental Training) Mini-School. And the Operation Swingback Mini-School had been redesignated as the High School Equivalency Mini-School.

The opening of the new school year brought with it a new and serious problem with the streetworker component. The Board of Education the previous spring had agreed to pick up the streetworker salaries at the same scale—\$8,000 to \$10,000—the streetworkers had received the first year under the Ford Foundation grant. But the Coalition's Calvin Ramsey, who had recruited the streetworkers, was unable to get a written commitment from board officials.

In fact, it was not until after school opened in September that word was received from 110 Livingston Street (school board headquarters in Brooklyn) that the streetworkers could be hired. But they would have to go on the payroll as "school neighborhood workers," a position that paid only \$7,600.

Ramsey learned that salary lines for senior neighborhood workers at \$9,600 and principal neighborhood workers at \$11,900 existed. On the advice of school board personnel, he decided to put in applications for neighborhood worker positions at \$7,600, while attempting to negotiate reassignment to the senior neighborhood worker lines. All of the applications were held up by the Livingston Street bureaucracy and, in order for the streetworkers to be paid at all, salary advances had to be secured from the Board, still at the \$7,600 level. Ramsey attempted without success to secure loans from the Coalition and other sources for the streetworkers to bring their income closer to the level they had enjoyed the previous year. (The Coalition turned down the loan request on grounds that it preferred to keep salary funding at Haaren—including that for streetworkers—"in-system" and because of poor repayment experience with earlier loans.)

The situation created serious problems for the streetworkers, most of them young and many with families.

Things boiled over in November while Ramsey was out of town on a business trip. Checking in by phone with the Urban Coalition offices, he learned that the streetworkers, in his words, "had a little job action going." They had walked off the job in an effort to force Board of Education action on their salaries and had taken most of the students with them: Ramsey rushed back to New York, met with the streetworkers to explain his efforts on their behalf and ultimately persuaded them to return to work.

The streetworkers received their first regular checks (at the \$7,600 rate), rather than advances, early in December 1972. But it was not until the following March after long and frustrating negotiations that extended all the way to the staff of then-Mayor John V. Lindsay, that all but one of the streetworkers received promotions to the senior neighborhood worker salary line. The pay increases were retroactive only to December 24th.

Ramsey is inclined to attribute his and the streetworkers' frustrations not so much to individuals at the board, some of whom were very cooperative, but to "the system and how things had to operate . . . it was just that the procedures they (the Board staff) had to follow were totally incredible."

Despite endorsement of the increases at the highest

echelons, the request had to pass through so many Board of Education offices—high schools, Manhattan high schools, personnel, and budget, among others—that confusion and delay were almost inevitable. In one instance, the approval documents disappeared for several weeks, "lost" in a pile of paper on the desk of a clerical worker. They were not relocated until Ramsey made a personal visit to board headquarters to push the search.

Meanwhile, relationships between the streetworkers and others on the school staff had improved over those of the previous year, when the streetworkers were a new and unfamiliar element in the school and when they reported to a streetworker supervisor from the Urban Coalition rather than to the school administration. The supervisor, whom Ramsey said was needed the first year to protect the streetworkers' position, was removed and, beginning with year two, the streetworkers reported to the assistant principals in charge of their respective mini-schools.

It cannot be suggested that staff-streetworker relationships were totally without strain and occasional conflict. In fact, in one case a mini-school coordinator went so far as to demand that a streetworker be fired. He was not. But, in a number of cases, streetworkers were transferred from one mini-school to another because of personality conflicts with assistant principals or coordinators.

The new Professional Services Center, meanwhile, had come under the sole direction of Assistant Principal Jacobs, following the assignment of Ed Blaine to responsibility for the school's reading programs. Jacobs thus became responsible both for development of the center's programs and its management, creating for him a highly complex set of responsibilities.

Joseph O'Connell, the part-time consultant who had been helping the center from its inception, worked with Jacobs in an attempt to clarify the organizational and management structures of the center. Basic information was gathered on the center's functions and translated into an organizational chart tracing out line and staff relationships. Later, O'Connell conducted a time study of Jacobs' activities, turning up a problem afflicting not only the PSC but most elements of the Haaren structure.

The problem according to O'Connell is that, at Haaren and presumably at many other schools, the importance of meetings for purposes of planning, implementation, or communication, is not recognized by the staff—an attitude that probably is justified by their past experiences in the school system. The result is that, at Haaren, staff people seldom gather in formal meetings but tend to "grab each other in the halls." This meant, in Jacobs' case, that he was "at the beck and call of any one who dropped in at the

PSC" and spent a significant percentage of his working day with people who technically had no involvement with the center.

O'Connell converted his findings into a series of recommendations for the organization and management of the PSC. O'Connell's recommendations went to the newly-formed Management Development Office (MDO), one of a number of developments reflecting significant changes in the administrative structure at Haaren. The new office was headed by Edward McCormack, a data systems manager for the Equitable Life Assurance Society on a one-year loan to the school. Teamed with him was Jeff Zerowin, a former mathematics teacher, department chairman, and program chairman who had been named executive assistant to the principal and assigned to the MDO.

Zerowin and McCormack proved to be an interesting team. The latter, whose presence implemented the management director role agreed upon the preceding spring, was a businessman with a deep interest in and commitment to education. He had attended the School of Education at St. John's University and both his wife and brother were teachers in New York City schools. Zerowin, in turn, was an educator with a background—as a corporate vice president—in business and a deep commitment to the application of better management techniques not only at

Haaren but from "the top (the Board of Education)" on down" to the classroom level.

Prior to assuming his new post, McCormack took time off from his Equitable position and undertook his own survey of the Haaren situation at the end of the first year of mini-school operation. After interviews with the Board of Education, the Urban Coalition, the United Federation of Teachers, and Haaren administrators, staff, and students, McCormack concluded that the prospects were "grim but not fatal." He saw mini-schools as a possible solution but had reservations about the staff's commitment to the project and the effectiveness of support from the Board of Education. Commitment and leadership on the part of the principal, he concluded, would be the key to the success of the experiment.

Meanwhile, two new business loanees—Tony Christ of the New York Telephone Company and Emil Schell of IBM—were assigned to Haaren. At the outset, their roles were similar to those of the previous year's loanees, limited primarily to contacts with potential corporate supporters and such projects as the organization of a Junior Achievement program in the school. What was needed, according to Zerowin, was more effective machinery through which the loanees' talent could be put to the best use.



Zerowin and McCormack, meanwhile, had initiated a series of systems studies covering such areas as school security, staff roles and responsibilities, and a school inventory. To aid in the studies and to help overcome the problem of better loanee utilization, Christ and Schell gradually were handed greater responsibilities in the project. The result was, as will be seen later, that the following year's loanees were formally assigned to the MDO.

At the same time, significant changes had occurred in the Urban Coalition's involvement in the project. Under the direction of management consultant Tyson, the Coalition had gone through a three-day soul-searching effort to determine whether it was getting a satisfactory return for its substantial investment in both money and talent. The Coalition, it was concluded, could and should be involved in the planning phases of all aspects of the project. But, as Zerowin put it, it was politically very difficult for Coalition personnel to act as implementers.

What was needed was an arrangement like that developed between Zerowin and McCormack in the new Management Development Office. There, the two men worked together on such projects as the security systems study. But "outsider" McCormack kept a low profile when it came to issuing reports and recommendations, all of which went out over the signature of "insider" Zerowin.

There followed a series of meetings between Principal Deutchman, the Coalition's McCagg and Gray, McCormack, and Tyson, which produced agreement on the creation of a formal instrument for the introduction of new programs in the school. Called the Haaren Planning Group, the new body included Deutchman, two assistant principals, a guidance counselor, a mini-school coordinator, a streetworker, an MDO representative, the UFT chapter chairman, and Coalition and business representatives.

Subsequently, all proposals for new programs or projects, whether they came from within the school, from the Coalition, or elsewhere, were submitted to the Planning Group. There, the proposals were reviewed, modified, and, if favorably received, forwarded to the principal and his cabinet for final approval and implementation.

Existence of the Planning Group provided what amounted to a set of checks and balances between the Haaren staff on one side, and the Coalition (and other outside agencies) on the other. It provided a means, according to Zerowin, to "legitimately" introduce programs or reforms suggested by the Coalition staff. And, perhaps most significantly, it represented a move toward a solution of a problem plaguing Haaren and most other schools -- the lack of effective planning.

"I don't think most schools have either the time or staff to plan effectively," Zerowin commented. "Adequate planning time seldom is set aside and the schools end up with crisis management."

But, with the advent of the Planning Group, Zerowin added, "people now stop to think for a second" before adopting new programs. He pointed out, for example, that when a new course—such as one in home repair—is proposed, time now is taken to evaluate its impact on the budget and other aspects of school operation before it is adopted.

Year Two also saw the school's physical planning efforts move into high gear. Preliminary schemes for two mini-schools, developed the preceding year, became the subject of a design seminar held at the Parsons School of Design and organized as a formal course for the spring semester of 1973. Participants in the seminar included seven teachers, two streetworkers, and six students from Haaren, a representative of the school board's Office of Educational Facilities Planning; Chuck Dickinson of the Urban Coalition, and two Parsons faculty members. A grant of \$1,100 from Educational Facilities Laboratories helped underwrite an overall budget of \$2,065, covering tuition, the development or acquisition of models, films, and literature, and documentation. The balance of the funds came from

Haaren's budget and from partial tuition payments by teacher participants from Haaren.

Out of the seminar came not only a final design proposal for the two mini-schools but a pattern for effective involvement of students and staff in environmental planning for a school and an effective approach to coordinated use of available resources—the public and private sectors, foundation, and universities. In addition, it is expected that the Haaren plans will serve as a prototype for other schools interested in the imaginative renovation of their facilities to accommodate new programs.

Actual renovation work has yet to begin as of this writing. Commitments of \$1 million for the work have been made by both the Board of Education and the city's Board of Estimate as part of the 1973-74 capital budget. But, at last word, budget modifications needed for a final go-ahead still were tied up in the Budget Director's Office and it was not clear whether work could start during the next academic year.

### THE SUMMER OF '73

As suggested earlier, a major emphasis in the Haaren Mini-School Project was a commitment to avoid a shortcoming of most of the earlier mini school and street academy projects—the lack of evaluation. The first tangible results of

the commitment came during the summer of 1973, with publication of the results of an interim evaluation of the project.

The evaluation, based on a design developed by an in-school committee at Haaren, was attitudinal in nature and intended to provide answers to a series of questions.

- Did faculty and students perceive that their mini-schools and the total school complex were achieving their goals and objectives? Did they feel that planning for both organizational structure and programs were effective?

- Did faculty and students identify with their mini-schools and regard them as cohesive units?

- Was there a clear perception of the various roles of such staff members as assistant principals, mini-school coordinators, guidance counselors, streetworkers, and school-wide administrators on the part of all participant groups?

- Had clear leadership patterns emerged for both the mini-schools and the total complex?

- What were the patterns of communication in the school, particularly for faculty and students?

- Did students feel they were learning anything of value and that there was continuity in their learning experiences?

- Had mechanisms for self-evaluation been developed by individuals, the mini-school, and the school at large?

- Were student services both effective and coordinated?
- What was the general attitude of faculty, students, and parents as to the success to date of the mini-school experiment?

After a study of proposals from a number of agencies, the evaluation contract was handed in April 1973 to the New York firm of Fox and Fox Associates. The information was collected, primarily through the use of specially designed questionnaires, in May and the findings submitted to the school in mid-June, in time for use in planning for the 1973-74 school year. (The formal printed report, however, was not issued until August.)

The findings were mixed. Teachers, for example, were found to "perceive the mini-schools with ambivalent feelings." For them, the mixture of successes and continuing failures are daily experiences. On the positive side, the majority felt that faculty-student relationships had improved, that they had a better perception of student needs, and that the streetworker input was a positive influence. And, most said they identified with their mini-school but "paid a price" in a sense of alienation from their colleagues in the rest of the school. (It should be noted here that faculty relationships in the past generally had been formed along departmental lines, with the disappearance of departments, many of those relationships were disrupted.)

On the other hand, students had the most positive view of the project. The majority of those who had lived through the transition found that Haaren had improved since the introduction of mini-schools. And nearly half felt their own behavior—including attendance—had improved, as had their relationships with other students and with teachers. And most had positive attitudes about the quality and relevance of classroom instruction.

On the negative side, teachers complained that discipline had not been improved and, in some cases, had deteriorated. They felt that the school's problems with attendance, truancy, and cutting had not been resolved and that academic achievement, the lack of adequate equipment and materials, and the employment of teachers outside their licensed discipline continued to be problems.

Administrators were more critical of the project than were teachers. Like the teachers, they cited discipline, truancy, cutting, and attendance as problems and blamed "permissiveness" in student lounges as a contributing factor in disciplinary problems. But they showed greater concern than teachers with such questions as mini-school autonomy (which they felt had not been achieved), bureaucratic red tape, unavailability of the principal, and "a lack of leadership."

The report concluded with what the authors termed "an impression not tied to any specific piece of data but rather coming from the overall experience of planning and conducting this evaluation. . . .

"This impression, stated simply, is that something good is happening at Haaren High School, reflected in an extremely broad-based involvement in this experiment and that this involvement is as clearly expressed in the strong feelings of those who have negative attitudes and opinions as it is in the feelings of those who were positive. One senses that a considerable majority of the staff is now actively involved in evaluating where they have been, how far they have come, and in considering alternative ways to go from here. The evaluation staff believes that this involvement, coupled with the air of intellectual ferment, one senses, augurs well for the future success of the mini-school reorganization."

Despite its upbeat ending, the report was to have adverse reverberations in the school. The problem was that, whether or not the authors so intended, some teachers felt the report over-emphasized the role of the streetworkers and slighted the efforts and achievements of the teaching staff. As Mrs. Maggie Glotzer, former UFT chapter chairman, put it during a meeting with the author, "the Fox and Fox report is overweighted in favor of the streetworkers."

It is true that it was the streetworkers who were most consistently cited as making difference in the school. But it must be remembered that the evaluation was a survey of attitudes and that the streetworkers were a new and therefore highly visible element. Accordingly, their good showing in the study would seem only logical and not to be taken as a criticism of the teachers, who had been in the school all along and who had the more difficult task of living through and adapting to change.

But the teachers' reaction to the report is indicative of the sensitivities involved in reform efforts like that at Haaren. There had been similarly adverse reaction from the staff to two advertisements—one by Mobil and one by the First National City Bank—describing their involvement in and contribution to the Haaren project. Both ads had been subject to review by Deutchman, who was joined by Mrs. Muriel Schwartz, the UFT chapter chairman, in reviewing the Citibank ad. And both were revised before publication. Nevertheless, to some staff members the ads implied that Haaren personnel were incapable of dealing with the school's problems and that only through corporate intervention was the school "saved" from total collapse.

The fact that, more than a year later, the ads still were the object of staff resentment suggests that great caution—on the part of both corporate sponsors and the school

administration—be taken in publicizing experimental school programs. Haaren staff members, for example, still ridicule the action of then Chancellor Scribner in calling in press and television newsmen to cover the Haaren experiment only days after the project was launched.

The fact is that premature or ill-considered publicity can do much to create friction between a school staff and those who attempt to help them in a reform project. At Haaren, the result was active distrust on the part of many staff members, not only for the corporate advertisers but for the Urban Coalition. That distrust culminated in a faculty decision, in a two-to-one vote early in 1974, to refuse formal cooperation with the author in the preparation of this book. The author was not denied permission to enter the school and, as it turned out, no staff member, including those with unfavorable views of the project, refused to be interviewed. The adverse vote, some staff members later admitted, reflected a feeling that the book was intended to "make the Coalition look good" and therefore could not benefit the staff. It was not, they added, a vote against the author per se.

On another front, a major effort was undertaken during the summer to improve management procedure at Haaren. An Education Management Planning Workshop, held July 9-27, included Deutchman, his assistant principals, mini-

school coordinators, McCormack, Zerowin, and business loanees. Out of it came the Haaren management manual or what has come to be known as the "blue book," a massive document ostensibly covering every aspect of school operation.

The manual opens with a description of each mini-school, followed by a separate statement of objectives for each. A subsequent section sets forth the roles and responsibilities for each category—assistant principal, advisor, coordinator, teacher, streetworker, and so forth—of the school staff. Finally, it offers a series of guidelines covering virtually every procedure—admissions, attendance, book ordering, implementation of curriculum packages, dealing with student cutters, student discharges, discipline, development of educational objectives, to offer some examples. In most cases, the guidelines are translated into Gantt charts, which break the overall task down into sub-steps and provide a step-by-step schedule for their accomplishment.

Opinions as to the value of the workshop and of the manual vary considerably. Some faculty members interviewed took the position that the workshop was little more than a boondoggle, for which the participants were well paid. One went so far as to claim that the manual actually had been written during the preceding school year and

"simply typed over the summer." And, he added, "the finished product was nonsense . . . the Gantt charts were absolutely, totally worthless."

But Zerowin, who with McCormack planned the workshop and supervised development of the manual, offered a different and more positive view. He conceded that the manual was being put to better use at the administrative level than at the teaching level and that the teachers still had problems and frustrations in dealing with school procedure. It would take time, he added, for the full impact of the manual to be felt. But in the long run, there would be improvements, including a reduction in paper work at all levels. He pointed out that the blue book was constantly being updated, revised, and improved. And it should be noted that the manual was very favorably received by Samuel Polatnick, assistant superintendent in charge of the city's high schools, who took the trouble to write Principal Deutchman to praise the effort in producing it.

Meanwhile, the teacher training effort continued. Two of the existing mini-schools—Coordinated Curriculum and SHAFT—were scheduled to be merged in September to form the new Haaren Prep for ninth year entering students. Accordingly, an effort was made to provide a training and curriculum development program for the teachers assigned to the new mini-school. Ultimately, Board of

Education funds were obtained to conduct a five-day workshop, held in the Union Carbide building, conducted by a faculty team from New York University's School of Education, and attended by six Haaren Prep teachers. Workshop goals, according to Harold Vine, the NYU team leader, were to give the teachers better skills in the teaching of reading, regardless of their discipline; to produce an integrated program, and to develop a mini-school staff identity, team spirit, and commonality of purpose in both teaching and approach to students.

The teachers were encouraged to re-examine what they were teaching and how they were teaching it. Stress was on the development of content relevant to the students, then on the development of a presentation that would make the content enjoyable, effective, and lasting for the student. Science teacher Liz Fong, for example, had determined that human biology was a subject of great interest to her students. Workshop leaders urged her to try a less lecture-oriented approach to teaching the subject. Miss Fong now employs a much livelier, activity-oriented approach that helps her students learn through discovery. And she now is regarded by many of her supervisors and colleagues as one of the more effective teachers at Haaren.

### YEAR THREE: A TIME FOR CONSOLIDATION

The end of the summer also brought the end of Ed McCormack's assignment at Haaren and his role as management director. As planned, control of the Management Development Office and the management director's title was handed to Zerwin, making that office even more a Haaren-controlled operation. Meanwhile, two new business loanees—Bill Davis, a computer specialist for IBM, and Atiba Kee, systems analyst for Western Electric—were assigned to the school. This year, they were to not only work with the MDO, but be formally assigned to it and work directly under the management director, now a full-time Haaren staff member. A third business loanee—Bill Hall of the Touche Ross Company, a major auditing and management consulting firm, was assigned on a one-day-per-week basis.

During the year, the loanees conducted studies of the school's attendance office, its inventory system, and its total resources—people, equipment, and materials. A study of the student record maintenance system—New York high schools are required to keep student records for 30 years—resulted in a proposal to eliminate a cumbersome filing system taking up five rooms worth of space

and replacing it with a microfilm system that would store all 200,000 student files on 20 reels of film in two file drawers. The system was to involve an initial cost of \$5,177, including hardware, of which the Coalition was to provide up to \$3,000. Annual operating costs were estimated at \$613. The proposal went to Board of Education head quarters for approval and has yet to be acted upon.

Hall, meanwhile, was working with three mini-schools—Aviation, Automotive, and Pre-Tech—to determine how well their staffs managed their time. Similarly, Kee set up a working relationship with the Careers and English as a Second Language Mini-Schools and Davis worked with Haaren Prep and the Business Co-op Mini-Schools.

A substantial share of Kee's time went to the organization of a school-wide health fair, an effort that brought mixed results. A first, educational phase of the fair was to include use of English and science classes for a two-month period to heighten student awareness of health problems. Ultimately, only two weeks were allocated, during which students filled out questionnaires on their health background.

During phase two, three days were devoted to medical tests administered by the Lower West Side Medical Center.

Some tests required parental permission and 80 per cent of the participants showed up with completed consent forms. Overall, the student response was gratifying: 600 were expected to participate, more than 850 actually showed up. Phase three, again conducted in cooperation with the Lower West Side Medical Center, involved follow-up with students in need of medical or related services.

Theoretically, the health fair was to be run by three in-school committees. One was to work with outside health agencies, the second to handle publicity, and the third was a student committee. Meetings were held to solicit help from staff and students. But there was little response. Committee chairmen did not follow through on their assignments. The result, according to Kee, was that all the work was done by only four or five people and that it was "very tough" to maintain schedules.

Experience with the health fair symbolized the frustrations encountered by the loanees at Haaren. They claimed that at least three of the school's assistant principals were "out-and-out opposed" to any approach to systems development or accountability. "Our mere presence at the mini-school level," said Davis, "was perceived by some assistant principals as jeopardizing their professional status."

While the "opposition" AP's did not veto systems develop-



ment efforts, according to the loanees, they disapproved and simply refused to lend their support, effectively slowing down the program. Other AP's, with a more favorable attitude toward and commitment to the project, resented what they considered to be "foot-dragging" on the part of their colleagues, but there were no open conflicts over the issue.

Overall, the loanees found a "surprising lack of professionalism" at Haaren. But they felt there had been progress, that the mini-school concept was a good one, giving students a place to call their own and teachers the opportunity to work with smaller numbers of students. Further, said Davis, the teachers "can be exposed to the necessity for management techniques as opposed to crisis management and at least see the value of looking ahead." But, they concluded, a critical factor still was missing—leadership from "very strong" assistant principals capable of lending accountability and guidance to the mini-schools and helping them to develop as planned.

The opening of the fall semester also saw the introduction of a new phase of the teacher-training program. Harold Vine's NYU team was brought in to help upgrade the teaching of reading in the school, concentrating at the outset on the Haaren Prep Mini-School. As he later admitted, Vine started work under two preconceptions that turned

out to be misconceptions. The first was that reading specialists could provide all the help that was needed in giving reading instruction skills to teachers of all disciplines. The second was that he, Vine, could conduct all of the staff training.

The training program included two all-day conferences, presumably devoted to the analysis of teaching objectives and development of coordinated curriculums, supplemented by weekly staff meetings. The all-day sessions were marked by confusion, particularly in efforts to arrange field trips that would free teachers to attend the meetings. At one session, a sizable group of teachers arrived well after the starting time, blaming Ed Blaine, the assistant principal in charge, for "dropping the ball" by failing to notify them of the meeting.

As Blaine sees it, "it took a long time to work out effective relationships between the Haaren teachers and the NYU team and the results were not uniformly successful." Vine agrees. Things reached a point, he said later, where the project "seemed to be falling to pieces. I was furious and ready to pull right out of Haaren. When I returned to Haaren a week later, I actually didn't know what to do next."

The problem had to do not only with the fiasco caused by late arrivals at the preceding week's session, but what Vine

felt was "an unwillingness on the part of the teachers to focus on their problems and to think things through." At the same time, he had the feeling that Blaine's attitude was that the NYU help was neither needed nor wanted.

At this juncture, according to Vine, Blaine stepped in with a solution. As Vine remembers Blaine's suggestion: "I think we've got to coordinate our efforts. I'd like you to visit classes with me, attend meetings with me, work with me on book selection and all the rest. We should work as a team of equals."

Vine agreed, as he puts it, "that began the breakthroughs . . . I never thereafter went and worked with a teacher unilaterally. It was a phenomenal learning experience."

What Vine had learned was that the mechanics of consultation are delicate, that both sides need to be open to criticism, and that "people learn and grow and develop in stages. There are just so many things you can expect from them at any one time." At the same time, Blaine had acquired "a whole new attitude" toward teacher supervision. Where once he observed teachers only, once or twice a year and concentrated on technique and conformance to the lesson plan, Vine said, Blaine now makes a series of "mini-visits" to each teacher's classroom and concerns himself more with what actually is happening to the

student. But Vine does not take credit for Blaine's transformation or the overall success of the program: "He (Blaine) willed it. I could not have done it all."

One lesson was clear. University-based consultants in teacher-training programs have as much need for in-school machinery to give their efforts legitimacy and effectiveness as do business loanees, agencies like the Urban Coalition, and management consultants. And a second lesson was learned. Teachers in other subject areas came up with questions the reading specialists could not handle, with the results that specialists in mathematics and science were brought in to supplement the NYU team. At any rate, the NYU involvement at Haaren, once a near-disaster, now is regarded as the most successful of the teacher-training programs yet undertaken at the school.

That success, according to Blaine, was due primarily to the fact that Vine and his team had developed a sensitivity to the problems of the school staff rather than, as often is the case with consultants, "coming in with the answers and trying to impose them." In addition, the program was designed to provide frequent, if brief, consultations on a one-to-one basis with all teachers—an effort, as Blaine pointed out, that no assistant principal could afford to make.

Efforts continued, meanwhile, to improve the organization and operations of the Professional Services Center. By the spring of 1974, in its fourth semester of operation, the center had produced 52 new courses for the various mini-schools. With the help of a consulting team from the City University of New York, it had employed television for teacher self-analysis and inaugurated a training program in the use of audiovisual equipment.

A professional library was developed and expanded by accumulating materials already in the school and by outside purchases. In a joint PSC-library project, mobile units were developed to provide audiovisual services to the mini-schools. And, under a contract with Open Channel, a non-profit public access television operation, an attempt was made to develop televised curricular projects, experimental teaching programs, and the use of public access TV as a means of communicating with Haaren parents.

But it was clear that the PSC still was not performing fully in the rôles originally envisioned for it. For one thing, the center still had not become a magnet for the staff, a place where teachers gather to share ideas and experiences. Some blame the center's location on the sixth floor, which they claim is inaccessible despite the fact that it is opposite the teachers' cafeteria. The more likely explanation is that the staff either is unaware or unconvinced of the value of using

the center. "It is a matter," Deutchman commented, "of getting the teachers accustomed to its use."

A more serious problem, in the eyes of many teachers interviewed, is the fact that many of the PSC-developed courses were prepared by teachers who were not on the staff of the mini-schools for which they were intended. The result, say the critics, is that some of the new courses are irrelevant to the mini-school programs and little used. Deutchman concedes that the problem exists, but attributes it to procedures imposed by the state funding under which the center operates. The procedures impose delays in the assignment of substitutes for teachers assigned to curriculum development, so that assignments tend to be *ad hoc*, involving teachers who can be spared at the time.

"It's true that, on the surface, the wrong people have been assigned to the job," Deutchman maintained. "But we had to do it the best way we could."

A share of the blame for the relative ineffectiveness of the PSC was accepted by the Coalition's Lynn Gray, who developed the original operational plan and now concedes that the plan was more conceptual than operational. It is not surprising, therefore, that a major emphasis in the Urban Coalition effort at Haaren for 1973-74 was to help

strengthen the PSC so that, by the end of the year, it would be an effective and self-perpetuating operation.

Much had to be accomplished if that objective was to be achieved. The PSC, according to Gray, was not a smoothly managed organization. There was no clear understanding of what it is, how it works, and how it manages its own resources. Few, if any, staff meetings were being held, with the result that there was little continuity between projects. Gray also felt that Carroll Jacobs, assistant principal in charge of the center, lacked the management skills to run such a complex organization and spent too much time on proposals and evaluations and too little time helping his staff to understand how to attain their objectives. The result, he added, was that the staff was somewhat "lost and floundering."

Several major decisions designed to improve the situation were taken at mid-year. One was to concentrate the PSC's curriculum development efforts and the NYU reading program in three mini-schools—Haaren Prep (where the NYU program had proven itself), Careers, and Senior—all of which offered non-vocational, non-technical programs and were basically weak links in the Haaren program. Teachers assigned to curriculum development would work side-by-side with NYU team members.

In addition, the video and audiovisual programs were to concentrate their efforts in the same three mini-schools. And, finally, an effort was under way through the Management Development Office to set up an effective procedure for regular reporting by the PSC to the principal.

The Coalition's interest in helping to develop a viable PSC extended, in what was to be its final year of involvement at Haaren, to all major components of the school. As Gray put it, "by July 1974, it was our objective to leave every mini-school with a competent management team, clear objectives, effective auditing procedures, and a precise connection to the next-level mini-schools."

The last objective had to do with the desirability that there be enough communication and cooperation between mini-schools that a student leaving Harlem Prep, for example, would find himself prepared to tackle the curriculum of whatever tenth-year mini-school he chose to attend. And, hopefully, such articulation would be accomplished without sacrificing the autonomy of the individual schools.

To date, it does not appear that in-school communications have improved to the point that the mini school programs can be effectively articulated. In fact, many faculty

members and administrators complain that it is difficult to maintain continuity in any one mini-school program because of the frequent transfer of teachers, coordinators, and assistant principals from in-school to mini-school and because so many teachers are assigned to more than one mini-school. A step toward solution of the problem was taken during the 1973-74 year by changing the rotation system to insure that teachers would remain with one mini-school for at least two years rather than, as had been the case, only a year.

The Coalition's last-year effort also extended to the Management Development Office and the Haaren Planning Group, the effort again premised on leaving them as strong, viable, and continuing elements in the school's operations. To help in the strengthening process, Coalition personnel agreed to channel all contacts with the school through the two offices and/or the PSC. The Coalition was to function more in a partnership role, according to Gray, and there would be "no more end runs" in which Coalition ideas were injected without consulting and working through one or more of the in-school agencies.

In the case of the Haaren Planning Group, the changes involved reducing the number of members from outside the school in favor of in-school personnel. After reorganization, Gray remained as the only Coalition repre-

sentative and Cyril Tyson worked with the group as an outside consultant. It should be added that, both before and after reorganization, the planning group was highly active, handling scores of suggestions and proposals—e.g., the health fair, development of a data bank, computerization of school records and programming, a comprehensive reading strategy for the mini-schools, and an inventory control system—that either were implemented, rejected, or sent back for revision.

In the Management Development Office, probably the most significant development came in February, when Zerowin was named assistant principal in charge of management, development, and planning. The move, which had to be approved by both Deutchman and his superiors at the Board of Education's Office of High Schools, meant that the MDO had gained full recognition as a formal and legitimate part of the Haaren structure. At the same time, it represented a tacit acknowledgement on the part of both the school and the Board of Education that management is a vital element in the educational process.

At about the same time, Murray Warren, who had been Haaren's assistant principal for administration, resigned to return to classroom teaching. After an open competition, Warren was replaced by Andrew Jones, formerly coordinator of the DeWitt Clinton Mini-School in the Bronx.

According to Gray, Jones and Zerowin formed a "strong and quick alliance." Both were serious and hard workers and became an effective team, committed among other things, to clearing up the administrative confusion in the school.

The result, according to Gray, was that the second half of the school year saw a much stronger MDO, enjoying an "increasingly sound view of school operations," and involved in such critical efforts as the total inventory of Haaren's resources mentioned earlier. Gray conceded that the payoff in MDO operations was not yet visible to individual teachers but predicted that, over the next two or three years, the office would develop the capacity to "really affect the school."

Parallel to its efforts to strengthen Haaren and its operational components, the Coalition was seeking ways in which the process of school change could be replicated in other schools. The search, as will be seen in Chapter Five, led to the establishment, in cooperation with the Board of Education, of a new training center designed to help schools undertaking restructuring projects like Haaren's. Under a grant from the National Institute of Education, the new center will support development of a mini-school complex at Intermediate School 162 in the Bronx.

Assistance will be provided for staff development, organization of a teacher center, the design of experimental training programs, and a study of the role of the community school board in the change process. A key project objective will be to clarify the process by which renewal or restructuring projects such as this can be effectively undertaken in the schools.

The center initially also will work with Intermediate Schools 52 and 125 in the Bronx and 201 in Manhattan in the preliminary phases of restructuring projects. And it will provide assistance to satellite mini-schools at George Washington and Washington Irving High Schools and Joan of Arc Junior High School in Manhattan, James Madison and Wingate High Schools in Brooklyn, and Port Richmond High School in Staten Island.

What can be said, meanwhile, about the success of the Haaren experiment? To provide some hard answers in terms of attendance, dropout rates, and student achievement, the school commissioned Fox and Fox Associates to conduct a full-scale, Coalition-financed evaluation of the program, the results of which will be described later in this chapter.

To an outside, non-professional observer, however, it seems apparent that the answers are not all in and will not

be available for several more years. Long and probing conversations with teachers, administrators, students, the Urban Coalition staff, streetworkers, business loanees, and corporate representatives elicited a wide range of opinion about the project and its success.

In fact, there seemed to be agreement on only one point. Virtually everyone agreed that the mini-school complex was either "a good idea" or "a promising concept." But opinions about Haaren's success in implementing the concept varied widely, apparently in part according to the individual's success in adapting to and operating within the new structure, programs, and methods instituted under the project.

Most observers, including Patrolman Nat Carey of the New York City Police Department, agree that Haaren is a "happier" place than it was a few years ago. Carey, whose beat has been Haaren since 1969, noted that the school was "a shooting gallery" for hard drugs when he first arrived. Today, he added, hard drugs no longer are a problem. But, there is some use of marijuana and alcohol is a growing problem. There have been no new riots. But, while there were no burglaries in the school during 1973-74, Patrolman Carey reported that the previous year burglars "ripped off" more than \$50,000 worth of school equipment.

On the other hand, some teachers and administrators complain about student behavior, particularly in the mini-school lounges. One went so far as to charge that the shift to mini-schools had produced "anarchy" in the school.

And, among those who see Haaren as a happier school, a violence- and drug-free school, there is no agreement that the mini-school project is responsible for the new climate. Some attribute the change to broad shifts in the political climate that has seen a decline in student unrest and drug use in schools and on campuses across the nation.

It is clear that, despite development of the Haaren Planning Group, the Management Development Office, and the Professional Services Center, much more needs to be done to make the Haaren mini-school complex a smooth-running, well managed operation. Despite changes in the managerial structure, many teachers, outside observers, and even some administrators feel that Haaren is "over-managed" and that the advent of the mini-schools brought with it the addition of still another managerial structure—the mini-school coordinators. In fact, some have suggested that the school's middle management positions could be cut by a third to a half with no reduction—and probably an improvement—in efficiency.

Similarly, it is apparent, that a number of the school's

assistant principals are not happy in their new role as administrators of mini-schools and, at least privately, would prefer to return to their old roles as subject-matter chairmen, with direct supervision of the teachers dealing with the subject matter. And most management specialists, including Management Director Zerowin, feel that all of the school's administrators including those who have accepted their new roles, could benefit by programs designed to improve their skills as managers, planners, and organizers.

On the surface, at least, some of Haaren's mini-schools—notably English as a Second Language (ESL), Pre-Tech, and College Bound—have been more successful than others. Some attribute this to the interest and dedication of the teachers involved, which at least in the case of ESL would seem to be partly the case. But others, like Neal Remland, Haaren's UFT chapter chairman, point out that the successful mini-schools all grew out of programs already operating in the school when the project was started.

Remland, interestingly enough, questioned the viability of the theme approach to mini-school organization, which, he argued, tends to deal with symptoms and not the causes of student problems. A more effective approach, in his view, would be to group students according to family

structure—all parentless youngsters in their own mini-schools, all from mother-dominated households in theirs, and all from "normal" households in theirs. With such groupings, he calculated, teachers could learn to deal with the more or less common problems generated by common family conditions.

Haaren's "new" staff component, the streetworkers, apparently retained their favorable image in the eyes of students and most faculty members. But approval is not universal. On the positive side, one teacher commented that:

"The streetworkers are serious, committed people. They have their own style in relating to students. The kids identify with them and they have a "street sense" about the kids. They get down to brass tacks and the kids understand very well. But they maintain an air of authority."

On the other hand, another teacher felt the streetworkers were guilty of "a lot of goofing off," although he conceded that "some of them try." And still another teacher, who called the streetworker concept "excellent," felt that, to the extent they were attempting to get truants and cutters back into the classroom, the streetworkers were "out in the street looking for a ghost."

The streetworkers themselves generally expressed interest



in and satisfaction with their jobs. But they also had their frustrations. Cited most often was what the streetworkers felt was a tendency on the part of teachers to "dump" the paperwork involved with attendance and behavioral problems on the streetworker. The paperwork and the time spent in contacting, by mail or phone, the parents of truants, they argued, cut into the time available for direct contact with students. Some also felt that too much time had to be spent covering the student lounges and that the streetworkers staff should be doubled.

And there were frustrations with their status in the school. At the outset, the Coalition arranged a program under which the streetworkers could seek professional advancement by enrolling at the City University. Some actually attended classes the first year but most had to drop out during the salary crisis in year two of the project and when financial assistance was not forthcoming. The result is some resentment of both the Board of Education and the Urban Coalition for failing to provide a career ladder the streetworkers felt had been promised them.

To Principal Deutchman, the streetworkers appeared to be a mixed blessing. He noted that "the general public response" was that the streetworkers "have been valuable to the program." And he said that the streetworkers had "developed good relationships with students," that they

were "essential" in their role as supervisors of the student lounges, and that their presence had "improved the tone of the school." But he said there were unresolved problems with the streetworkers—problems he declined to specify for the record—that he had not found time to resolve. "We can't," he said, "tackle all of the problems at once."

The ambivalence of the streetworker situation at Haaren may have serious import for the future of the streetworker concept in the New York City schools. Budgetary cutbacks have seen the disappearance of streetworkers from all but Haaren and one or two satellite mini-schools in the city. (Some satellites never had a streetworker component.) If streetworkers do not remain an integral part of the Haaren operation, it is unlikely that streetworkers and their critical role in dealing with students and their problems will be included in the funding for future school-reform projects.

The streetworkers' frustrations are reflected elsewhere in the staff. Teachers in particular complain they are unable to acquire needed materials and supplies and that there is too little support from and communication with all levels of the administration. As one teacher put it:

"There are too many administrators running around the building rather than deciding how they can help us do our

jobs. There are too many chiefs. No one really listens to our needs."

On the other hand, the same teacher put her finger on what the Haaren project—and other efforts at school reform—is all about. There were, she said, "huge barriers of comprehension" between teachers and students, created by student deficiencies in English, complicated in many cases by health and psychological problems, and/or the unwillingness or inability of teachers to understand or relate to their students.

"You can't just be a teacher," she said. "You have to be a sister and a social worker."

"Some teachers," she added, "don't teach. They just keep the kids quiet. To do that is to fail them." Whether that kind of sensitivity—and it is shared by many of the Haaren faculty—combined with Haaren's mini-school organization and its new approaches to planning, management, and teacher training can produce measurable changes in the achievement, performance, and behavior patterns of the students becomes the critical question.

Some answers are provided by the comprehensive survey of achievement, attendance patterns, and dropout rates conducted in the spring of 1974 and published the following semester.

Results of the comprehensive survey of achievement and attendance patterns, conducted in the spring of 1974 and published the following semester, suggest that the answers are not yet in. Comparisons of achievement levels during the 1970-71 school year and those for 1973-74 indicate that, over the first three years of its existence, the mini-school complex had no *school-wide* effect on the academic averages scored by Haaren students:

On the other hand, significant gains were found in the achievement levels of students in five of Haaren's twelve mini-schools. In three cases—College Bound, Haaren Prep, and Mobil Co-op—the percentage of students with academic averages above 70 per cent were consistently higher and the percentage with averages below 60 per cent consistently lower. In a fourth mini-school, English as a Second Language, gains were shown in the number of students with averages above 70 per cent. And, in the Pre-Tech Mini School, improvement was indicated by findings that the percentage of students with a average below 60 had dropped significantly.

There are no hard survey findings to indicate why progress was achieved in these mini schools while, in some others, achievement levels actually declined. (Studies of student absence and lateness patterns proved equally inconclusive.) But speculation on the part of David Fox, who

headed the evaluation team, may be of significance.

It is highly possible, Fox suggested in an interview, that the new learning environment represented by Haaren's mini-school complex provided a climate in which those mini-school teams that were better organized and motivated could produce significant gains in student achievement. That suggestion is reinforced by the fact that the mini-schools showing the most significant gains tended to be those in which mini-school identity and programs seemed to this observer to be most fully developed.

Accordingly, it may be reasonable to conclude that, given the continuance of the mini-school project at Haaren, the climate should permit the strengthening of programs and teaching patterns in other mini-schools and, ultimately, improvement in their academic performance.

Indeed, it is reasonable to argue that a final assessment of the Haaren project is premature at this point in time. Many of those interviewed in preparation for this book felt that at least five years was needed for radical reform of the sort involved at Haaren to take hold and produce measurable results. But Haaren has had only three years to "turn itself around" and, given the near-chaos of the project's first year, effectively only two years in which to implement real change.

The conclusive answers, then, would appear to lie in the future. Haaren, as will be seen in the following chapter, will continue to operate as a mini-school complex and to adjust and refine its programs, instructional approaches, staffing patterns, and organizational and managerial structures. It thus should continue as an active and promising laboratory for reform in urban secondary education.

## Chapter 4 (Part 2)



Schoolmaster, 1631.

## Focus on: Developing Human Resources

Conversion of Haaren High School into a mini-school complex meant, among other things, that virtually the entire school staff would be placed in new roles and would be required to perform new and unfamiliar functions. To equip them to perform in these new roles, it would be necessary to provide training programs.

Teachers, for example, required training in:

- The small-group, team, and interdisciplinary approach to instruction called for by the mini-school organization;
- The ability to take on greater responsibility for the guidance function;
- An understanding of the role of the streetworker and the ability to work with this new member of the school team;
- The involvement of students in the planning and operation of the mini-schools;
- Curriculum development, and
- The use of specialized audio-visual equipment in the instructional process.

Similarly, many people in administrative positions—particularly the new mini-school coordinators—required training to fill new roles imposed by the new school structure. And training was required if the newly assigned streetworkers were to fit effectively into the school structure. (See "Focus: Streetworkers" later in this chapter.)

The training program at Haaren essentially took three basic forms: special summer workshops, for which the participants were paid; organization of a

Professional Services Center, through which teachers were granted reduced teaching loads in order to develop new curricula, and programs in reading instruction and the use of audio-visual equipment and techniques, conducted by university-based consulting teams.

As has been seen, these various efforts had mixed results, ranging from near-total failure of the 1971 summer workshop, to qualified success in the summer of 1972, to the still-unrealized potential of the Professional Services Center concept, to important breakthroughs, in the second half of the 1973-74 school year, in a reading-instruction program conducted by a New York University team in cooperation with Assistant Principal Ed Blaine.

As this record indicates, much remains to be done before the objective of a continuing and effective program of staff retraining is realized at Haaren. For one thing, there clearly is too little communication between mini-schools and other elements in the school structure. Even within mini-schools the level of communication varies, with the most active dialogue to be found in the more successful mini-schools.

The importance of a continuing dialogue was indicated in a series of group interviews conducted in preparation for this book. The groups were diverse: one included assistant

principals, the librarian, teachers, and streetworkers. In every case, it appeared that individuals in the group were learning as much or more from each other than the interviewer was learning from the group. That impression was verified on a number of occasions, when group members reported to the interviewer that they had gained a great deal from the sessions. A few even volunteered to attend additional sessions for that reason.

Theoretically, the Professional Services Center should provide a forum for such dialogue but, as has been seen, it has yet to be used for that purpose. A step in the right direction came in 1973-74 with the introduction of an in-service training program enrolling about a dozen teachers. Entitled "Multiple Strategies: A Reading Workshop," the program was aimed at setting up a dialogue that would cut across subject areas and, as Ed Blaine put it, "strengthen a school-wide philosophy that teaching is not a day-to-day affair but a process that requires planning, the solution of problems, and continuous give and take between teachers."

Obviously, there is need to reach more than a dozen teachers if there is to be an effective, school-wide dialogue. One possibility may lie in the restructuring of mini-school staff meetings. These regular sessions, according to most

observers, now deal largely with procedure. But, if they were to be converted into effective planning sessions, with a clear-cut agenda, and objectives and strong leadership, the result could be an active dialogue, better mini-school planning—and effective training.

And it has been suggested that the approach could be carried a step further by the establishment of a school-wide committee charged with planning for the coordination and articulation of mini-school programs. The committee, which might have a rotating membership, could become the focal point for a true school-wide dialogue.

Finally, according to both Haaren and Coalition observers, the Professional Services Center needs strengthening. The Center's objectives and administrative structure both are in need of clarification before it can perform effectively in its critical teacher-training and curriculum-development functions.

But, no matter how effective the retraining effort, it appears unlikely that Haaren in the foreseeable future will boast a staff that is totally committed to its programs and totally effective in implementing them. The problem, according to observers like NYU's Harold Vine, is that the New York City school staff includes "hundreds of incompetents" and that schools like Haaren, because they are less

attractive to teachers than high schools in the more affluent outer reaches of the city, have more than their share of them. Or as Ed Blaine put it: "There are a lot of dead people here."

None of this is to suggest that "incompetents" make up the bulk of the Haaren faculty. There are and always have been effective and dedicated teachers at the school. But it is to suggest that the "utopia" of a 100-per-cent dedicated and effective staff probably never will be realized.

It must be added that there has been some visible progress. Ed Blaine, for example, estimated that there was a "20 or 30 per cent improvement" in the staff between February 1969, when he joined the school, and 1974.

"The teachers," Blaine said, "are younger, more dedicated, and have a better grasp of the realities of the learning situation."

## Planning Organization and Management

Haaren High School in the spring of 1971 was organized along typical lines for a New York City high school, with a structure not unlike that for most of its size across the United States. The administrative hierarchy started with the principal, Bernard V. Deutchman, and ten assistant

principals, all of whom plus a representative of the school's chapter of the United Federation of Teachers, made up the school's cabinet. With the exception of two assistant principals—one in charge of administration and the other responsible for guidance—all of the AP's were in charge of subject-matter departments: English, mathematics, social sciences, science, languages, physical education, industrial arts, and art.

Teachers in the various departments reported to the assistant principal in charge, who in turn reported to the principal. In addition, there were more than 50 different service, support, administrative, and staff/community-relations functions—ranging from the dean to the cafeteria, to health services, to union relations, to public relations, to curriculum administration, to the library. All were responsible to and reported directly to the principal. There may have been some delegation of these responsibilities to the assistant principal-administration, but ultimate decisions were made at the principal's level. Similarly such guidance-related functions as psychological services and employment counseling reported directly to the principal, not through the assistant principal-guidance.

Remembering that the principal in turn was responsible to the central school administration through a chain of command starting with the high school office for Man-

hattan, thence to the city-wide Office of High Schools, and from there to the Chancellor and the Board of Education itself, the kaleidoscopic nature of in-school responsibilities under his direct control would seem overwhelming and unmanageable. On the other hand, since direct responsibility for the critical area of teacher performance in the classroom was vested in the assistant principals-supervision, it might be argued that the principal was free to maintain direct supervision over the school's more peripheral functions.

But the fact is that, for administrative and other reasons, the school was not functioning. It was, in Deutchman's own words, "a school deteriorating before our eyes." It was to deal with that reality that the mini-school project was inaugurated in 1971. The broad intent of the project was to individualize and humanize the educational process and make it more relevant and effective for the student clientele.

To do so, the project called for the creation of small, autonomous teaching units—the mini-schools—each with its own programmatic theme, coordinator, guidance counselor, and streetworkers. The mini-schools were to be small enough to give their students a sense of place and identity. Closer relationships between students and teachers were to be encouraged. There was to be an inter-

disciplinary, team approach to instruction. And new curriculums were to be devised to meet these objectives. Obviously, the new school structure would be more complex than the old. A new and more efficient managerial structure would be required.

But the start of the project brought little change in the managerial structure. Ten assistant principals, eight of them still retaining authority over teachers in their subject areas, continued to report to the principal. And the principal still dealt directly with the full range of peripheral functions and services, the number of which had been increased by new relationships with the New York Urban Coalition, with the streetworker component, with business loanees, and with corporations that supported a number of the new mini-schools.

To complicate matters, creation of the mini-school complex added a new element—the coordinators of 14 mini-schools—to the managerial structure. And, under the table of organization then in force, all 14 reported directly to the principal and not through the assistant principals. The only concession of the new school structure was a restatement of the duties of the assistant principals-supervision.

While they would continue to be responsible for course content and supervision of instruction in their subject

areas, the supervisory APs also were to encourage curriculum revision, adaptations, and development of innovative and experimental methodology which will be made possible through the new type of structure." And they were to "encourage, to an even greater degree than heretofore, experimentation, innovation, and flexibility of approach and method."

"It is further recognized," the statement continued, "that there are many procedures which can be utilized other than—and in addition to—the previously followed traditional course sequences (in order) to build and develop the desired skills, knowledges (sic), attitudes, and outcomes."

All of this meant a dual and conflicting chain of command at Haaren. Teachers were forced to march to the tune of two different drummers—the subject-oriented assistant principal and the mini-school coordinator, who presumably was encouraging an interdisciplinary approach to instruction. Meanwhile, both the assistant principals and the coordinators were reporting directly to the principal, a situation that could not help but muddy the decision-making waters.

More serious, in terms of project objectives, the managerial structure meant that the new mini-schools



lacked any real autonomy and as a result, the sort of individual identity planned for them. In general, students did not identify with their mini-schools or with the mini-school staffs. Confusion and administrative short circuits were the order of the day. No one, especially the assistant principals and the mini-school coordinators, had a clear picture of his role, responsibilities, and functions.

The fact that the APs and the coordinators had overlapping responsibilities led inevitably to conflict between the two groups. The confusion and the conflicts remained unresolved until December, when Deutchman and a Coalition-organized business advisory committee began a series of meetings aimed at finding a solution.

The meetings, which consumed many after-school hours and much pulling and hauling between the committee, Deutchman, Board of Education officials, and the Coalition, led ultimately to the Holiday Inn management conference described earlier in this chapter and to adoption of a new structure under which each of the assistant principals had administrative control over two mini-schools but retained his school-wide authority over subject-matter teachers.

By spring, it was obvious that the new structure—known as "Plan A"—was a failure. The Coalition, which mean-

while had developed a three-year master plan covering its involvement in the project, met with Board of Education officials to urge adoption of a master plan for Haaren and to suggest that a management director's position be established at the school.

Ultimately, the Coalition master plan was adapted to Haaren's needs and viewpoints and adopted. A new managerial structure, under which the assistant principals' role was better defined to separate line and staff functions, was established. And it was agreed that a management director, to be nominated by the Coalition, would be appointed.

The new administrative structure, which ended all traces of the old departmental system, represented an improvement over the old. The lines of responsibility were clearer: the coordinators of two mini-schools reported to each of the assistant principals supervision, who in turn reported to the principal. But, in part because not all of the assistant principals are happy with the disappearance of the subject-matter departments, where in fairness they had built their careers, problems of the administrative structure still are not totally resolved. In fact, some of the APs feel that their inability to supervise teachers directly in their disciplines has had a detrimental rather than a positive effect on the school.

On the other hand, appointment of a management director clearly has had a positive impact. His presence, as expected, has made it possible for the principal to shed many of his concerns with administrative detail and focus more attention on the school's educational programs. Establishment of the Management Development Office (MDO), under the management director's control, has provided a vehicle for the more effective utilization of business loanees. See "Focus, Business Involvement" later in this chapter. And the MDO has been able to undertake a number of management and systems studies—most significantly a full-scale inventory of the school's resources—that very likely would not have happened in its absence.

As reported earlier, the MDO initially was headed by a business loanee—Edward McCormack of the Equitable Life Assurance Society—who worked with Jeff Zerowin, executive assistant to the principal. McCormack was instrumental in setting up the office and giving it direction. And he was astute enough to recognize that, since he was an "outsider" in an educational institution, MDO reports and suggestions to other school units should go out over Zerowin's signature. This meant that, almost from the outset, the MDO enjoyed a level of staff acceptance that otherwise would have been lacking.

Zerowin succeeded McCormack as management director

when the latter's one-year tour at Haaren came to an end. A few months later, Zerowin was promoted to assistant principal in charge of management, development, and planning, a development that greatly enhanced the office's status in the school and the potential for continued staff acceptance of its role. As Zerowin himself concedes, more time will be required before the full impact of the new office is felt in all areas of school operations. But, from all testimony, the MDO clearly represents a major step in the right direction.

A similar conclusion is indicated in the case of the Haaren Planning Group (HPG), the makeup of which is described earlier in this chapter. Organized primarily as a vehicle for the introduction and evaluation of program proposals originating both from within the school and from outside agencies like the Coalition, the HPG provides the potential for continuous planning and for continuing evaluation of the school's programs. (See handbook section of this book.) For a description of HPG operations, see the accompanying "idea to implementation" flow chart.

The restructuring of Haaren's management systems involved adoption of industrial management principles and techniques and their adaptation to the needs of an educational institution. Stress needs to be placed on the word "adaptation." Schools are not in business to produce

the measurable kinds of returns indicated by industrial profit and loss statements or income to investment ratios. The product of a school must be expressed in human terms—educated graduates, productive and emotionally adjusted citizens. The "returns" are difficult to quantify.

At the same time, the logic behind industrial management techniques can have a place in the educational scheme of things. The Haaren experience indicates that a major shortcoming in the schools is a lack of clear objectives. It is all well and good to argue that the objective is simply to produce an educated citizenry. But, given the failure to achieve that objective with any consistency, it is obvious that generalizations are not enough. There is need to establish more specific and detailed objectives that come to grips with the causes of failure, both in the schools and in their students.

In other words, the schools need to take a leaf out of the industrial-management book and institute what the management specialists call "management by objectives." They must develop a clear understanding of their problems and of the steps required to resolve them, then organize and manage themselves accordingly.

It cannot be claimed that Haaren High School today is a well-managed school. Much more needs to be

accomplished in restructuring and refining its management systems. But progress has been made and, as Assistant Principal Zerowin put it, administrators and teachers alike have come to recognize the hazards of "crisis management" and have learned "to stop and think for a second", before adopting new programs or procedures.

Outside assistance has been an important factor in the new management picture at Haaren. Early in the project, the business advisory committee, in a marathon series of conferences with Principal Deutchman, argued for changes in the role of assistant principals, changes that were at least partially implemented. The staff of the Urban Coalition's Education Program played a continuing role in the effort to restructure the school. And, through the Coalition, the business loanees and the school's first management director, Edward McCormack, made important contributions. And, again under Coalition auspices, the part-time services of management consultant Cyril Tyson were available to the school over a period of two years.

But the process of outside involvement was not an easy one. Relationships between the business advisory committee and Deutchman were far from smooth; to the point that the principal is said to have felt the corporate "experts" were trying to "push him around." Similarly, the Coalition staff was regarded with some suspicion in the

school and, in the view of some teachers and administrators, was both naive and arbitrary in some of its efforts to bring about changes in the school.

As Deutchman sees it, there were personality problems on both sides. There were occasions, the principal said, when he felt that Louis McCagg, Education Program director, "was trying to push me." "We had a number of disagreements about things he proposed but that I didn't think were wise or feasible at the time."

The problem ultimately caused the Coalition, with the help of Cyril Tyson, to re-examine its role in the project. Out of the re-examination came a new posture for the Coalition staff, one that was better attuned to the politics and practicalities facing an outside "intervenor" in a school situation. From then on, all Coalition efforts at Haaren were channeled through the school's own institutions—the Haaren Planning Group, the Management Development Office, and the Professional Services Center.

Significantly, maximum effectiveness of the business loanees at Haaren was not achieved until they were formally incorporated into the MDO. And the early effectiveness of the MDO itself was due in significant part to Ed McCormack's decision, as an outsider, to keep a low profile and channel the office's reports and proposals

through Insider Jeff Zerowin.

Taken together, Haaren's experiences in reforming its management structure and systems suggest a number of important lessons for both educators involved in reform and for outside agencies trying to help them. First, and perhaps most important, machinery should be established for the orderly and systematic handling of proposals for change, whether generated within the school or outside, by an agency of the school.

Second, many of those involved in the Haaren project have concluded that school administrators, particularly in a school as large and as complex as Haaren, should have formal training in modern management techniques. Some would go as far as to recommend a year or two in management programs, preferably tailored to educational realities, at an institution like the Harvard Graduate School of Business.

Finally, there are some among the teaching staff at Haaren who feel that no outsiders—such as the Education Program staff—should attempt to intervene in a school situation like that at Haaren without first having two or three years' teaching experience in a school with similar conditions, problems, and political realities.

# Haaren High School Planning Group Idea-to-Implementation Flow Chart

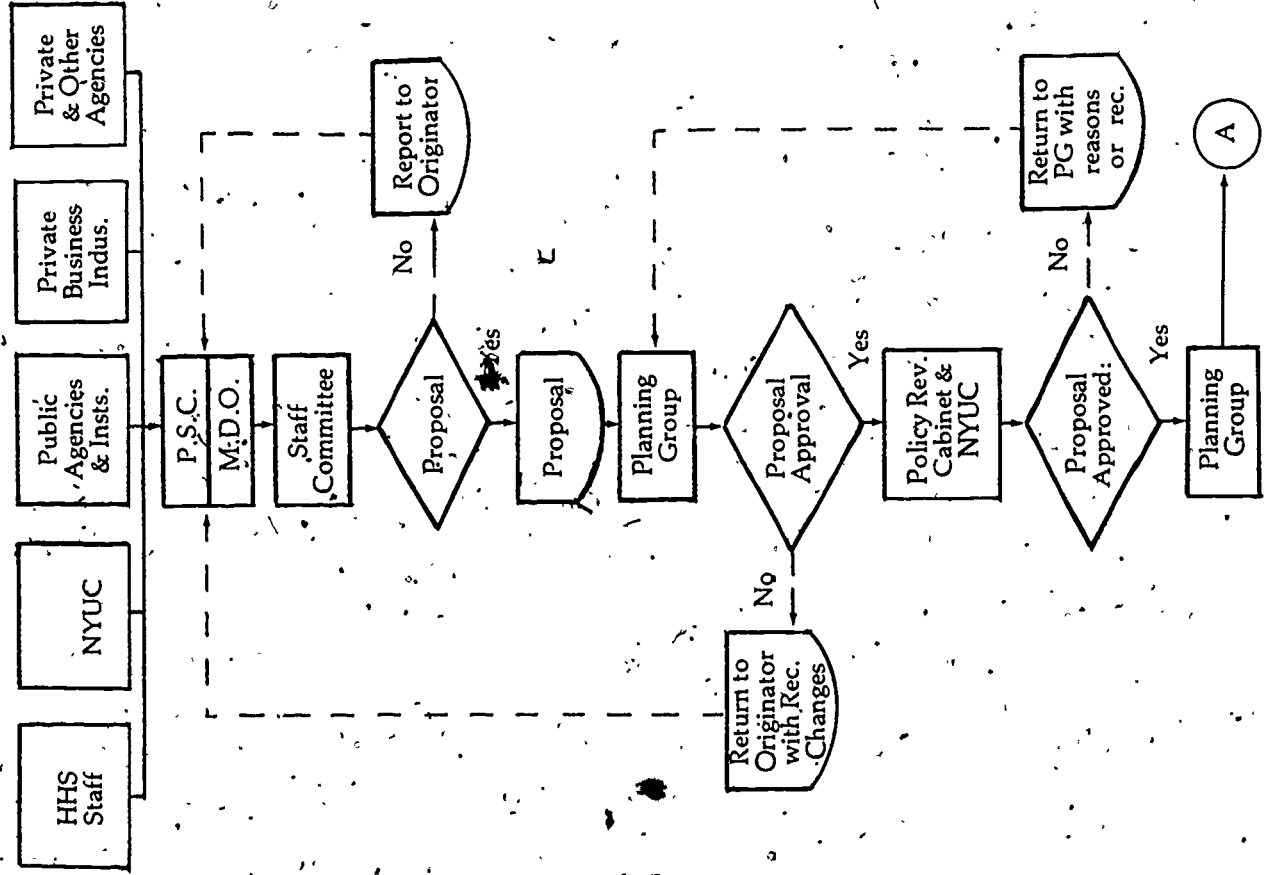

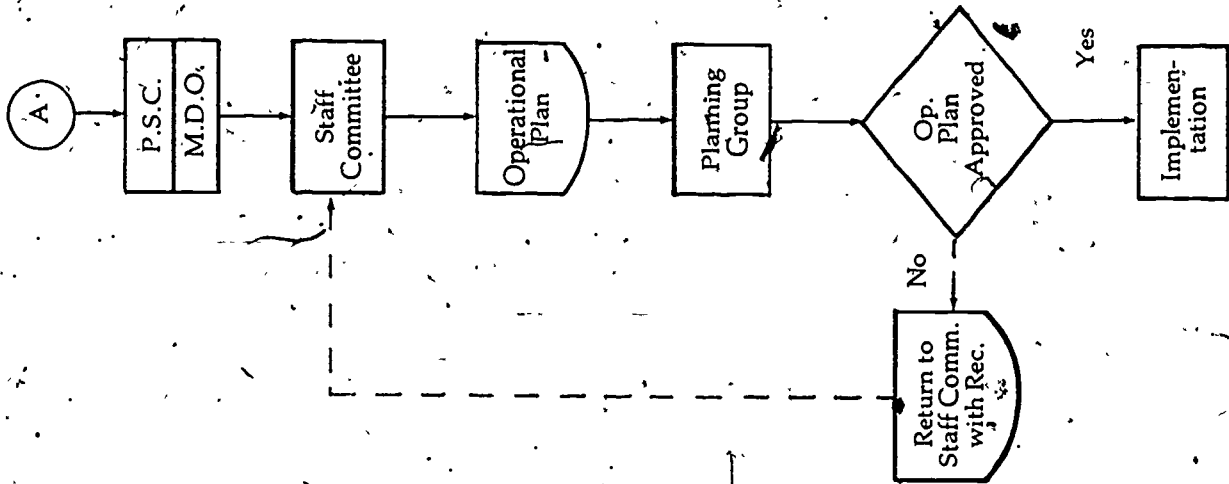

## The Physical Environment

Haaren High School, built in 1903, is cut out of the typical mold for urban schools of its era, a mold, incidentally, that was not to be broken until the late 1950s and still is reflected in the design of many new inner-city schools. The six-story structure, its exterior designed in an ornate, Dutch Renaissance style and its interior reflecting now-obsolete educational thinking, as it stands represents an obstacle to the success of the mini-school project.

Haaren was built around the concept of the self-contained classroom, in which a teacher of, let's say, English, spent most of the day in the same classroom while students shuttled from classroom to classroom at the summons of a bell. The pattern, known as the "egg crate" to modern educational planners, tended to lock the educational program into a fixed pattern—to the extent that student desks for many years were bolted to the floor in rigid and unyielding rows.

The building was not only educationally obsolete but, because of its age and other factors, had been slated for abandonment in the late 1940s. But enrollment trends and other priorities ruled out its closing and Haaren obviously still is very much in business.

It was in this physical environment that, in September

1971, the mini-school project was inaugurated. A key element in the project was the allocation to each of the 14 new mini-schools its own, identifiable area of the school building—in effect, its own "turf." Within that area, each mini-school was to have a student lounge, a move that would help students identify with their mini-schools. And the semi-autonomous nature of mini-school administration suggested that each have office space for coordinators, guidance personnel, and the teaching faculty.

Typical of schools of the egg-crate pattern, Haaren has large, double-loaded corridors that eat up considerable building space. Under the mini-school organization, student circulation through the building was drastically reduced. The large corridors no longer were needed and, hopefully, a significant share of corridor area could be converted to instructional and other uses. By the same token, box-like, inflexible classroom spaces provided under the egg-crate plan did not accommodate the variable student groupings called for under the mini-school project's team and interdisciplinary approach to instruction.

Minor renovation to accommodate the project was carried out during the summer prior to its inception but was far too limited in scope to provide a suitable environment for the mini-schools. This much was recognized early in the game by Chuck Dickinson, then the Urban Coalition's

liaison at Haaren. Dickinson, as reported earlier, encouraged all of the mini-schools to think out their space needs and come up with plans for renovation to meet them. He won support and encouragement from August Gold, head of the Board of Education's School Planning and Research Division. He involved the architectural firm of Max Urbahn Associates in the effort. And he secured the interest, advice, and later financial support from Educational Facilities Laboratories (EFL), a Ford Foundation-supported agency devoted to improved planning for educational buildings and facilities.

The result was a two-year effort to develop plans for two specific mini-schools, a basic skills mini-school and a vocational mini-school. The first year's effort was devoted to the development of preliminary plans by a team including faculty, students, and architects. During year two, the preliminary plans were turned over to the participants of a design seminar—including many of the original student and faculty team—at the Parsons School of Design. The seminar produced final plans for the mini-schools which were submitted to Gold's office and won a \$1 million commitment in construction funds.

As reported earlier, construction has yet to begin. But the planning effort was in itself an important contribution. For one thing, it demonstrated that students and teachers can

be effectively involved in planning the physical environment in which they will work. It demonstrated that diverse resources—the public and private sectors, universities, and foundations—can be brought to bear in orchestrated fashion on the planning effort. And it produced a prototype for other schools that may wish to renovate space to accommodate mini-school-type programs.

Finally, as a practical matter, it demonstrated that the Haaren building lent itself to radical interior "surgery" to accommodate new functions and programs. The renovation of schools of Haaren's vintage is not a new approach; its feasibility has been demonstrated in scores of projects across the United States.<sup>1</sup> But a reality facing each renovation project is the need to establish that physical rearrangements are structurally feasible, that renovation does not involve inordinate costs, and that it can be carried out within the constraints of existing building and fire codes.

While far from unique, the Haaren planning process is one that well could be followed by other schools contemplating renovation. The process started with a painstaking effort to define the goals of the mini-schools on three major areas—educational, administrative, and social-emotional—and from them to develop general space requirements.<sup>2</sup>



The requirements then were translated into specific space allocations for such functions as lounges, circulation, offices, small- and large-group instructional areas, workshops and laboratories, independent study areas, and storage. Finally, with the architects involved, the space allocations were translated into schematic plans.

As the accompanying drawings indicate, the schematics for the basic skills mini-school emerged as an open-plan design, calling for extensive demolition of existing walls in a fifth-floor wing of the school. And the vocational mini-school was to occupy hitherto-unused basement space adjacent to the school's large auditorium.

It is significant to note that the results of the first-year planning effort were almost totally reworked in the course of the Parsons design seminar, conducted during the spring of 1973 and attended by seven teachers, two streetworkers, and six students from Haaren. Where the year-one effort focused on the problems of utilizing furniture and equipment to define and organize an open-space environment, the workshop focused more closely on the relationship between physical environment and social interaction and the impact of that relationship on education. The new focus led to a reconsideration of the schematic design in terms of the original program of requirements and to revisions that are reflected in the accompanying schematic

sketches and form the basis for the school's proposal to the Board of Education for construction funds.

Meanwhile, the Haaren project not only offers a prototype for other renovation projects but has had an impact on future high school construction in New York City. August Gold, whose office has responsibility for the educational planning behind all new public school construction in the city, has decreed, largely on the basis of his exposure to the Haaren project, that all new high schools built by the city will include "some sort of mini-school facilities."

<sup>1</sup> Educational Facilities Laboratories has supported many such renovation projects either directly or through its New Life for Old Schools' project in Chicago. For a list of pertinent publications and their prices, write to Educational Facilities Laboratories, 477 Madison Avenue, New York, New York 10022.

<sup>2</sup> See *Mini-School News*, Vol. 3, No. 7, November/December 1973, pp. 2-11; 17.

Each of the schematic designs in this section were done by John Griffin and grew out of the Parsons Design Seminar.

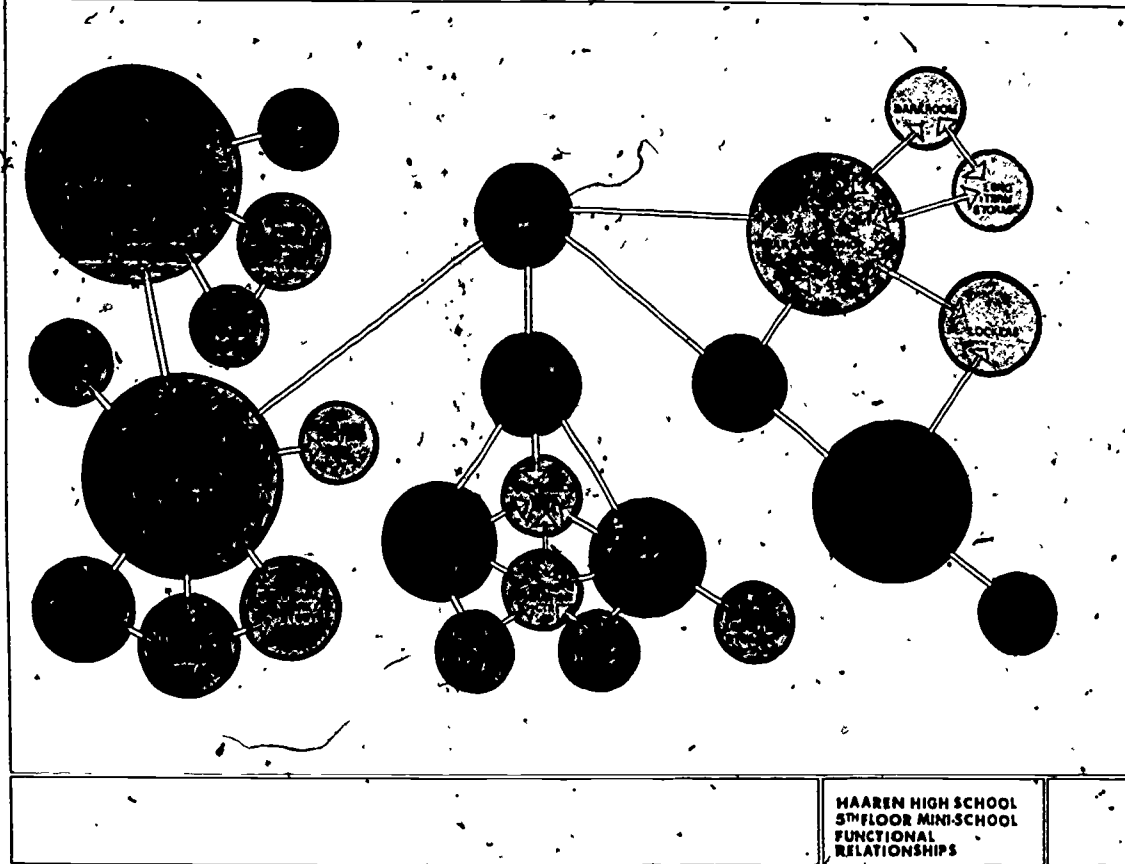

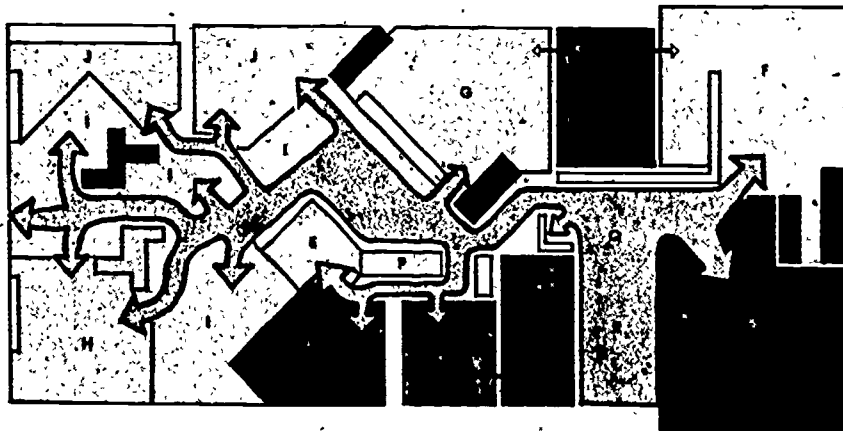

**KEY**  
 A LOUNGE/SEATING  
 B CIRCULATION  
 C STAFF OFFICE  
 D STUDENT OFFICE

E CONFERENCE AREA  
 F ART WORKSHOP  
 G MATH/SCIENCE LAB  
 H LARGE GROUP AREAS

I SMALL GROUP AREAS  
 J INDIVIDUAL WORK/STUDY  
 K RESOURCE CENTER  
 L DISPLAY/EXHIBIT AREAS

M LOCKERS/STORAGE AREAS  
 N LONG-TERM STORAGE  
 O PREP ROOM AND STORAGE  
 P REPRODUCTION CENTER  
 Q ENTRY

R STAIRS

**HAAREN HIGH SCHOOL  
 3<sup>RD</sup>FLOOR MINI-SCHOOL  
 SPATIAL  
 ALLOTMENT**

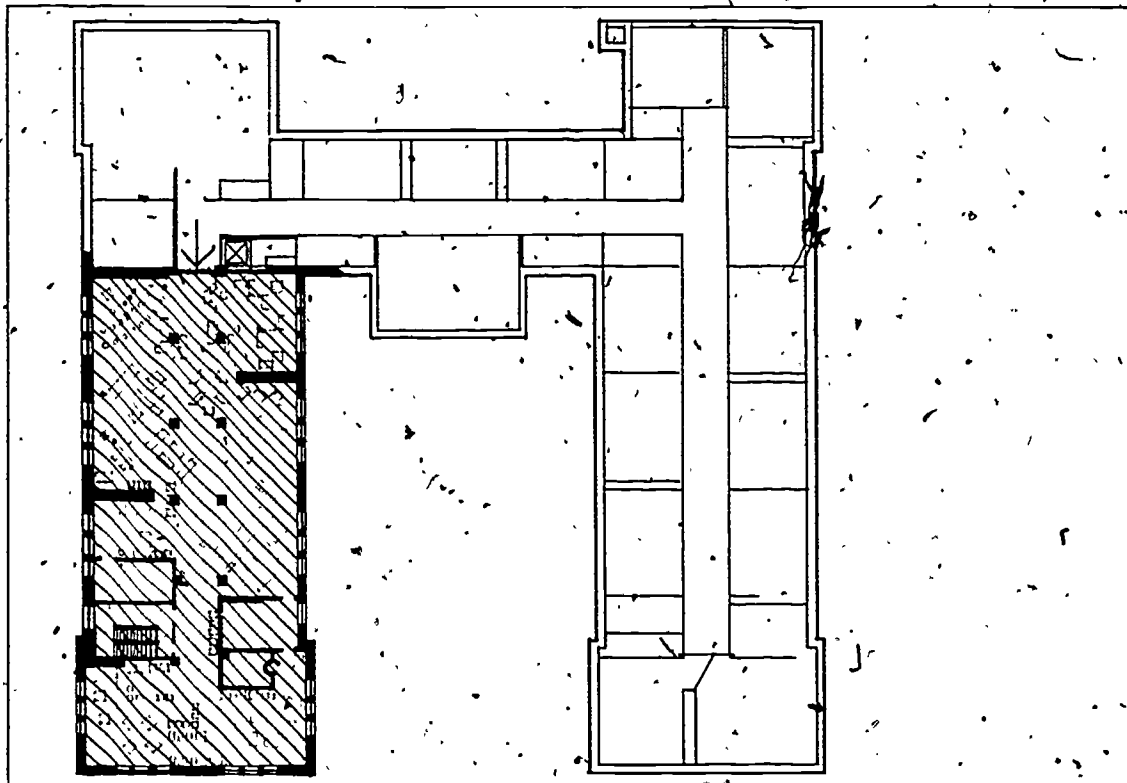

HAAREN HIGH SCHOOL  
BASIC SKILLS  
5TH FLOOR

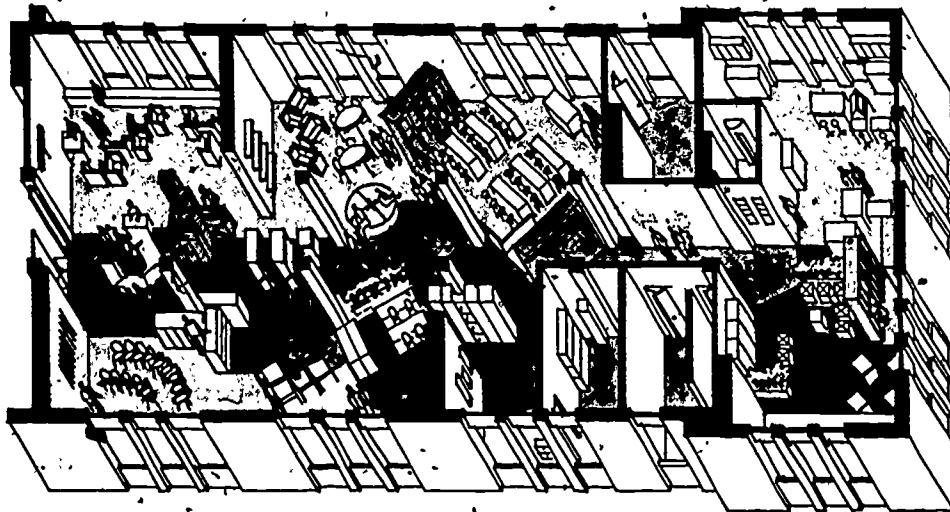

<b>KEY</b>	<b>A</b> LOUNGE/SEATING	<b>E</b> CONFERENCE AREA	<b>I</b> SMALL GROUP AREAS	<b>M</b> LOCKERS/STORAGE AREAS	<b>R</b> STAIRS
<b>B</b> CIRCULATION	<b>F</b> ART WORKSHOP	<b>J</b> INDIVIDUAL WORK/STUDY	<b>N</b> LONG-TERM STORAGE	<b>D</b> PREP ROOM AND STORAGE	
<b>C</b> STAFF OFFICE	<b>G</b> MATH/SCIENCE LAB	<b>K</b> RESOURCE CENTER	<b>P</b> REPRODUCTION CENTER	<b>O</b> ENTRY	
<b>D</b> STUDY OFFICE	<b>H</b> LARGE GROUP AREAS	<b>L</b> DISPLAY/EXHIBIT AREAS			

**HAAREN HIGH SCHOOL  
MINI-SCHOOL  
ISOMETRIC**

## Business Involvement

The phenomenon of business involvement in the public schools was not new when the Haaren mini-school project got under way in 1971. Prompted largely by the urban unrest of the 1960's and by difficulties in recruiting qualified inner-city residents to man their offices and production lines, many large corporations had committed themselves to attempts to resolve educational and other pressing urban problems.

In New York at least, the early corporate efforts were aimed at the support of alternatives to the public schools like the Urban League's street academies. Later on, as reported in Chapter Two, many corporate supporters grew disenchanted with the academies, primarily because it was felt they were mismanaged and were having little or no impact on the established school system. Accordingly, responsible corporate executives began to seek ways to tie the street academy concept into the existing schools.

The search resulted in establishment of the McGraw-Hill Street Academy, with its ties to Haaren, and later in corporate support of such projects as Harambee Prep and Wingate Prep, both attached to existing high schools. And ultimately it led to active corporate involvement with Haaren and its mini-school complex and the inclusion of

business involvement as one of the five basic components of the Haaren project.

With such involvement an institutionalized part of its program, Haaren in effect became a laboratory in which to test different approaches to corporate support and to determine which produced the greatest returns. For, historically, corporate involvement in the schools had taken a variety of forms, including:

- Outright budgetary support, in the case of the early street academies, for total school programs.
- Financial support of experimental programs within a school.
- Gifts of equipment and supplies.
- Partnerships under which corporations supported specific school programs related to their areas of interest—e.g.: Mobil Oil's support of an automotive mini-school at Haaren.
- Loans of specialized personnel to help in developing and operating specific school programs.
- Loans of managerial personnel to help solve a school's management problems.
- Financial, technical, and managerial support for innovative programs through such change agencies as the New York Urban Coalition and the Economic Development Council.

By the time the Haaren project came along, most of the involved corporations had shied away from direct budgetary support and from gifts of equipment. Such assistance, they reasoned, had little impact on a school's basic problems. Little was accomplished when a school administrator approached a corporation with a "shopping list" requesting such hardware as typewriters, furniture, television sets, or computers and with no clearly defined program for resolving his school's problems.

Gifts of specialized equipment were not ruled out in partnership situations such as Mobil's automotive program. But, by and large, the corporations were seeking ways to deal with the basic educational problems in the schools. They no longer were interested in a role as the rich uncle ready to pour money and equipment into the schools without regard for the return—in improved educational performance—on their investment.

Accordingly, the business involvement component at Haaren essentially fell into three categories: general support of the project through the Urban Coalition, continuing partnerships on the Mobil pattern, and the introduction of business loanees.

Support of the Coalition's Education Program continues, but at a somewhat reduced rate. And, as of the end of the

1973-74 school year and the Coalition's withdrawal from the project, that support ceased to have a direct impact at Haaren. Similarly, business loanees, who had been assigned under Coalition auspices, no longer are part of the Haaren scene. Only the Mobil-type partnerships remain.

But, meanwhile, much has been learned. Business, it turned out, made its most important contribution at Haaren in the areas of planning, organization, and management, first through the business advisory group, then through the services of Equitable Life's Ed McCormack as the school's first management director, and finally through the Coalition-generated consulting services of Cyril Tyson and, to a more limited extent, Joseph O'Connell. (See "Focus: Planning, Organization, and Management" earlier in this chapter.)

As was seen earlier, such involvement was not without strain and, at times, conflict. But the end result was that both parties—the insiders on the school staff and the outsiders from industry and the Coalition—found ways to bring outside expertise and assistance into the school through the school's own administrative machinery. In the process, the outside contributions gained legitimacy and acceptance by the school staff and conflict generally was avoided.

The business loanees at Haaren represent an important case in point. During the project's first year, the loanees occupied a separate office and, while they consulted with the principal on school needs and their efforts to help meet those needs, they essentially operated outside the school's regular administrative structure. As a result, according to some observers, they lacked visibility and thus any real appreciation of their contributions on the part of the staff. At the same time, their efforts tended to fall into the "shopping list" category. Much of their time was spent in seeking corporate help in acquiring equipment or assistance for specific school projects or programs.

The picture changed somewhat with the establishment, at the outset of year two, of the new Management Development Office. The loanees gradually were involved in MDO projects, such as studies of school security, and spent less time in soliciting corporate contributions and support. The following year, a new team of loanees was formally integrated into the MDO and, primarily for that reason, were in a position to make more significant contributions to the school than had their equally capable predecessors.

The lessons for educators seeking corporate support should be clear. Business is not interested in rescuing the educational system from its financial problems through grants of money or gifts of equipment (or, for that matter,

in any other form of indirect taxation). Nor does it have the resources to do so. But business, out of its own self-interest, is willing to do what it can to help the schools operate more efficiently and produce a better-educated and more responsible citizen who will contribute both to the pool of employable talent and to a more stable urban community.

In seeking business involvement, educators should recognize that reality, tear up their shopping lists, and seek the kinds of support that business is ready and willing to provide. And, once such assistance is made available, care should be taken to create appropriate in-school machinery to insure that the corporate input is regarded as a legitimate contribution to the school and its operations and not as an intrusion or interference on the part of outsiders from the corporate world.

## Streetworkers

The streetworker, when the Haaren mini-school project was initiated in 1971, was a relatively new and unfamiliar figure on the American educational scene. His origins traced back less than ten years to the start of the street academy program in Harlem in 1965. And it was not until 1968, when the McGraw-Hill Street Academy was set up



with formal ties to Haaren High School that streetworkers became part of the established school system in New York.

Furthermore, the streetworkers who were to become a major component in the Haaren project, were handed a substantially different role than that of their street-academy predecessors. The early streetworkers lived up to their name in every respect: their time was spent in the streets, seeking out school dropouts and employing methods ranging from persuasion to cajolery to outright bullying, attempted to lure them into the street academies to resume their educations.

In contrast, the streetworkers at Haaren spend most of their working day in school. Some time is spent in the streets checking the school neighborhood for truants and cutters. And, particularly during holiday periods, occasional visits are made to the homes and neighborhoods of truants and other problem students. In addition, the streetworkers frequently refer students to health, drug prevention, and other agencies for help in solving their problems.

But, despite all this, the Haaren streetworker still spends by far the greater proportion of his time in the building, a situation with which he is not entirely happy. Many of those interviewed felt that time could be spent more profitably in the streets. Most argued that each mini-

school should have at least two streetworkers, rather than the one which is the current norm. With two streetworkers assigned, they pointed out, one could handle in-school problems while the other was in the streets dealing with student problems from that vantage point.

Although the streetworker idea was "advocated" by whites like Harold Oostdyk, who adapted it from their experience in religious youth work, most of its practitioners today are minority-group members. At Haaren, for example, the recruitment process involved Blacks, Puerto Ricans, whites, and even a number of women. But the 15 finally selected were male and either Black or Puerto Rican. There was no attempt to exclude whites or women, but the school's selection committee felt that those selected appeared best qualified to function in the streetworker role.

The criteria for selection included related experience in such fields as athletic coaching, recreational work, and job or drug counseling; the ability to relate to young people from minority and/or poverty backgrounds and, at the same time, the ability to work with the teaching staff and other school personnel. Leadership qualities ranked high in the equation. And it was deemed important that students be exposed to a strong, male image from their own ethnic groups, a consideration that may have weighed against female candidates in the selection process.

Once selected, the streetworkers went through the summer training programs described earlier in this chapter and, in September, took over their new responsibilities. These included:

- Acting as counselor or "big brother" to the students, helping them with the full range of non-academic problems (academic problems are the function of the guidance counselors)—health, legal, behavioral, drug-related, employment, housing—encountered by inner-city youth.

- Acting as liaison or interpreter between minority and poverty background students and their middle-class teachers.

- Helping to maintain discipline in the student lounges, cafeteria, mini-school areas, and hallways. In that role, the streetworkers did not act as security personnel, did not regard themselves as such, and felt that, to do so, would undermine their ability in the eyes of the students.

- Communicating with the parents of student dropouts, truants, and cutters.

- Referring students with problems to appropriate municipal or private agencies.

- Assistance in the organization of student field trips, athletic and recreational events, and other non-classroom activities.

To offer a more specific picture of the streetworker

function, the following is a "log" of Haaren streetworker activities for the four-month period from September 1972 through January 1973:

- To deal with chronic truants and cutters, conducted 1018 students interviews, sent out 492 letters to parents, made 1313 phone calls to parents, and conducted 533 home visits.

- Maintained records indicating referrals, interviews, and other actions in dealing with student problems.

- In 20 cases acted as intermediaries for students at suspension hearings.

- Persuaded a number of potential dropouts to stay in school.

- Assisted students in contacting their guidance counselors and grade advisors.

- Handled student disruptions in hallways, lounges, and classrooms.

- Handled housing problems for 29 students.

- Helped 62 students obtain jobs.

- Helped in attempts to organize a viable Haaren parents' group.

- Helped organize student governments for the mini-schools.

- Contacted a grand total of 37 agencies to obtain help for 249 students. The scope of these activities may be indicated by a partial listing of the contacted agencies:

*Health-related*—Roosevelt Hospital, City College Mental Hygiene Program, Lower West Side Health Clinic, Bellevue Hospital Dental Clinic, Brooklyn Jewish Hospital.

*Drug-related*—Lincoln Center Anti-Drug Program, Bayview Narcotics Rehabilitation Center, Phoenix House.

*Employment*—New York State Employment Service, Opportunities Industrial Center, United Jewish Appeal, Job Corps, Vocational Foundation, Manpower, Jobs for Youth.

*Higher Education*—Hunter and Brooklyn Colleges, Columbia and Fordham Universities.

*Welfare*—New York City Department of Social Services.

*Legal*—Legal Aid Society, M.E.N.D., M.F.Y. Legal Services, U.S. Bureau of Immigration, Legal Probe.

*Housing*—West Side Crisis Unit, Emergency Shelter, Inc., Waverly Center, Children's Shelter.

Clearly, Haaren's streetworkers play an active and critical part in dealing with students and their problems. But, as they see it, their impact could be even greater. Attendance, they claim, is highest where teachers involve the streetworkers in classroom activities. But such involvement is rare, they report, primarily because most teachers do not regard streetworkers as professionals and do not want them in the classroom. The prevailing faculty attitude, according to the streetworkers, is, "If there's a problem, I'll send for you."

Ideally, as the streetworkers see it, all streetworkers should have had classroom teaching experience to function more effectively as streetworkers. Conversely, they argue that all teachers should have streetwork experience in order to better understand and communicate with their students. Food for thought.

## Chapter 5



## Educational Alternatives: The Future

As Haaren High School prepared to enter its fourth year as a mini-school complex, it was apparent that alternative forms of education had ceased to be mere experiments and had become an accepted part of the operations of many school systems across the nation. In New York City alone, it was possible to identify at least 50 mini-school operations as well as a dozen or more programs involving other approaches to alternative education. And, nationwide, the National Consortium for Options in Public Education reported that the number of alternative schools, or programs identified in the 1973-74 school year—575—was nearly 25 per cent greater than the total for 1972-73.

The possible variety in alternative schooling can be illustrated by a sampling of the programs already in being in New York City. In addition to Wingate and Harambee Preps, there were at least 30 satellite mini-schools in operation in the city during the 1973-74 school year and several new satellites were in the planning stages. Two new high schools—John Dewey in Brooklyn and August Martin in Queens—had been planned from scratch around innovative alternative programs. August Martin, for example, emerged from a cooperative community and school systems planning process with an aerospace-centered program. High schools throughout the city had students en-

rolled in the Board of Education's Co-op program, in which students alternate terms between school and work. Similarly, under an executive internship program, city high school students were splitting their time between formal schooling and internships in city agencies. A number of satellite academies were offering health services programs in cooperation with hospitals and medical centers in the city. And at least one elementary school - Community School 129 in the Bronx - acting on its own initiative has converted into a complex of small sub-schools.

Perhaps the most drastic of New York's alternative programs was City-as-School, in effect an urban "school-without-walls." Patterned after Philadelphia's widely publicized Parkway School, City-as-School, has no physical facilities other than a central office and counseling complex at a Board of Education building downtown Brooklyn. The school's 200-odd students attend "classes" in such diverse locations as the Bronx Zoo, the Richmondtown Restoration on Staten Island, a congressman's office, and the Federal Trade Commission's New York office.

Despite all this activity, it would be premature at best to suggest that alternative programs are available in New York for all students who desire them and might benefit by them. Trevor Cushman, who recently conducted an in-depth study of the city's high schools for the Chancellor's

Center for Planning at the Board of Education, suggests that it is "very misleading" on the Board's part to equate the existence of the alternative programs now in being with the real changes needed in the system. Cushman, formerly on the staff of the Fund for the City of New York, argues that, while "the total market for alternatives is enormous, very few kids really have an option."

On the other hand, much has happened in the last few years. And, while it cannot yet be described as an unmitigated success, the Haaren project stands as evidence that radical surgery can work in the system. For Haaren will continue to operate as a mini-school complex, at least for the foreseeable future. The project has the support of the principal and a solid majority of the staff. And no one interviewed in preparation of this book, including some teachers whose attitude must be described as critical or lukewarm, advocated that the concept be abandoned in favor of a return to traditional educational patterns.

There will be changes and adjustments as the project proceeds. Principal Deutchman suggests that there may be additional changes in the role and functions of his assistant principals during the years ahead. Consideration is being given to the possibility of phasing out another of the project's less effective mini-schools. And, in an effort to offset the loss of the old subject-matter-oriented depart-

mental structure, regular conferences of subject matter specialists will be instituted.

The changes, according to Deutchman, are part of what he says from the outset has been "a flexible approach—one that I am proud of." The staff, he added, has "constantly been analyzing our situation, our progress, and problems" and in an "aggressive and alert" fashion, has suggested and implemented appropriate changes and adjustments in the school's organization and program.

Change also will occur in the Urban Coalition's involvement in the process of school change. As was seen in Chapter Four, 1973-74 marked the final year of direct Coalition involvement in the Haaren project, although, according to Lynn Gray, Haaren will continue to enjoy an "open opportunity" to make proposals to the Coalition for new types of assistance when and if the need becomes apparent.

Meanwhile, Haaren's model for the mini-school complex has attracted attention among school administrators elsewhere in the city. At least nine schools—all at the intermediate or junior high school level—have approached the Urban Coalition with requests that it help them with the process of totally restructuring their organizations and programs. In response, the Coalition laid plans for a

research project, to start in the summer of 1974, under which one of the four, Intermediate School 162 in the Bronx, will be developed as a "pilot process model school." The project, conducted in cooperation with the School of Education of the City College of New York, is expected to generate "a renewal process and mechanism for the development of an efficient, manageable means by which to develop and extend mini-schools and mini-school complexes." It is supported by a three-year grant from the National Institute of Education.

The project is being conducted in cooperation with the Board of Education's Division of Planning and Support, headed by Dr. Edythe Gaines. This recently organized division for the first time in the city's history provided a central coordinating structure at school board headquarters for all experimental programs in the system.

The Coalition and the Board's Learning Cooperative (part of Dr. Gaines' office) are cooperating in the establishment of a program that promises to have a more widespread impact on the development of mini-schools and mini-school complexes in the city school systems. The program, called the Training Center and located at the Urban Coalition offices, is specifically designed to assist the staffs of schools which have developed or are developing new organizational and managerial patterns along mini-school lines.

The center will help school staffs in the process of setting objectives and in the management and organization of their new programs. Aid will be provided in curriculum development, the design of new physical facilities to house the new programs, and the utilization of new resources. And, in a third major area, the Training Center will assist in the development of leadership skills, improved interpersonal relationships, and the evaluation process. Support will be provided to schools indicating an interest in renewal to help them plan for renewal and in retraining their personnel to handle new programs.

Involvement of any one school in the Training Center sequence will be a two-year process, opening with a consultation period of from one to six months, during which the project will be designed by school and Coalition representatives, after which a formal proposal will be submitted to the Coalition. Approval of the proposal is followed by a pre-operational phase, during which broad objectives are clearly defined and a precise operational plan is developed. At the same time the school and the Coalition negotiate over resource allocations, timing, and the decision-making process, culminating in an agreement defining the operational plan for project implementation.

The project then enters its "in-service" phase, during which training support, both in personnel and resources, is pro-

vided for the first full year of operations. Finally, there is a 12-month-long follow-up stage, involving gradual and complete transfer of responsibilities to the school staff and development of a final report and evaluation of the project.

The Training Center approach, developed out of the Urban Coalition's depth of experience with the early street academies, the Wingate and Harambee Prep experiments, a group of satellite mini-schools, and the Haaren mini-school complex, provides a mechanism for the hoped-for replication of mini-school complexes in schools across the city. And the climate for such replication seems to be favorable.

That is not to suggest that all schools in New York (and elsewhere) be converted to mini-school or other alternative formats. As suggested earlier, there is and probably will continue to be a considerable segment of any school system's student body that can survive in and profit from a traditional educational program. What does seem possible in the long run is that traditional schools will become just one of a broad series of options open to all students in a given school system.

In New York, for example, Chancellor Irving Anker has proposed a cluster system for elementary schools, under

which each of the four or five schools in a cluster will differ in structure and/or programmatic emphasis. Parents, probably in consultation with guidance counselors, then would have the option of choosing the school they feel best suited to the needs of their offspring.

Another straw in the wind is a recent and unpublicized policy adopted by the Board of Education's Division of School Planning and Research, under which some space designed to accommodate alternative teaching patterns will be built into all new high schools in the city.

Perhaps more dramatic are a series of new projects planned by the New York City Educational Construction Fund, in which special-interest mini-schools will be built into new commercial or residential structures in the city. The Fund, a unique, state-chartered agency, is empowered to float bonds, build schools, then sell or lease the air rights over the school for commercial or residential development. Proceeds from the lease or sale, plus an annual fee paid by the developer in lieu of taxes, are employed to retire the bonds.

Until recently, Fund projects, while architecturally of greater interest than most recent school construction, have been planned around more or less traditional educational programs. But now, the Fund, in cooperation with the Division of School Planning and Research, proposes to

build an International Language Arts Center into a new apartment structure on Manhattan's Third Avenue. The Center will be a mini-school, accommodating 150 to 200 students, and will offer programs in such rarely taught languages as Modern Greek, Chinese, and Japanese. Close ties are envisioned with the nearby United Nations headquarters and with university language departments.

Another mini-school, specializing in communications, is contemplated at a location near the New York Daily News and another four or five—devoted to such subjects as small business, home improvement, child care, and electromechanical repair—are under consideration by the Division of School Planning and Research.

In short, in New York City and elsewhere, the movement toward "alternatives for everyone" seems to be gaining momentum. But the process is unlikely to be quick and easy. In New York, the Board of Education and its top administrative personnel are on record as favoring the widespread development of alternative programs. But there is a major reservation, suggested in a recent statement by Dr. Seymour P. Lachman, former board president:

"I am of the opinion that educational alternatives should be made available to the greatest extent possible. These alternatives usually are more costly and the limited



resources available to the Board of Education often prohibit the necessary proliferation of alternative schools."

"I hope that more funds might be forthcoming from foundations as well as from federal, state, and city funding sources to enable the Board of Education to provide the widest possible range of alternative educational programs for young people in the school system."

There is little question that, particularly as it is perceived by school officials, the funding of new alternative programs is a problem. But the Haaren experience suggests that Dr. Lachman may have been overly concerned with funding as a problem. When approving the Haaren project back in 1971, then-Chancellor Harvey B. Scribner imposed the requirement that it involve no additional expense to the Board of Education. While it can be argued that resources provided by and through the Urban Coalition amounted to expenditures over and above the normal school budget, the letter of Chancellor Scribner's instructions was followed, with one exception: streetworker salaries, which were taken over by the board beginning in September 1972.

The Haaren experience also suggests another problem that may tend to slow the proliferation of alternative programs: the need to develop new expertise in planning, organization, and management in the people who

administer the schools. At Haaren, for example, assistant principals who had spent their administrative careers as subject area chairman found it difficult to adjust to a new role in which they served as managers of mini-schools. Some observers have gone so far as to suggest that, in order to handle the complexities of what might be called the new educational management, administrators and future administrators should spend a year or more at an institution like the Harvard School of Business. The objective would not be to duplicate industrial management techniques but to develop new and effective approaches to the planning and management of large and newly complex educational enterprises.

Similarly, the spread of alternative programs will depend in part on the skills and attitudes of the teachers in the system. The new educational programs and techniques involved in the Haaren project, and in other school reforms, require different capabilities, including the ability to manage a less-structured educational environment, on the part of the teachers.

The resulting need to retrain the administrators and teachers now in the schools need not, however, cripple the movement toward alternative schools. There appears to be no reason why the required training cannot be offered on an in-service basis, particularly through the

development and refinement of mechanisms such as the Coalition's Training Center.

Teacher attitudes pose a somewhat different problem. While exceptions to the rule are legion, teachers as a group are not the most venturesome of people and regard change, particularly when untried programs are involved, with apprehension and suspicion. The problem is complicated by the growth of teacher unionism. Teachers who not too long ago did not enjoy the right of collective bargaining tend to be jealous of recently gained contractual provisions governing their working conditions and to resist any reform that may seem to threaten them.

In New York, for example, the powerful United Federation of Teachers has a formal policy favoring alternative education but, according to George Altomare, its vice president for high schools, "not at the expense of teachers." The UFT, in other words, is willing to cooperate in and even encourage experimental programs so long as they involve no increase in teaching loads, no lengthening of the work day, and no watering down of "professional quality" through such things as the use of paraprofessionals in actual teaching situations.

The union, Altomare said, is willing to make exceptions in unusual circumstances. He cites the example of John

Dewey High School where the Board of Education requested that teachers accept an eight hour day in order to carry out that school's experimental new programs. The normal teacher day is 6 hours and 20 minutes. The union agreed to the proposal with the proviso that the 8-hour day be mandatory for a period of no more than two years and that a separate payroll be established to compensate the teachers for the extra time, thus treating the extra work as an additional job.

In New York and elsewhere, union resistance should not be an obstacle to reforms, provided the Haaren pattern is followed and teachers and their union representatives are involved at the outset in the planning process and in the negotiations over the nature and consequences of the proposed reform.

If the climate for extensive introduction of alternative programs seems favorable, speculation about which of the alternative forms will survive and proliferate produces answers that are less clear cut. In New York, at least, the satellite mini-school attached to an existing high school currently is the most commonplace of the alternative organizations. But, at this writing, effective mechanisms for the support of these schools have not been fully developed. There is no central machinery for the continuing evaluation of such programs. Nor is there a clear

chain of command connecting school headquarters and the satellite schools; different schools report to different administrative offices depending on their origins and the source of their funding. And the satellites generally exist at the pleasure of the principal of the parent school.

All of this means that the satellites are in some danger of failure, either through lack of effective support from the top or because the parent-school principal is, or becomes, unenthusiastic or downright unsympathetic to the mini-school idea. Nevertheless, the Urban Coalition feels they should survive and for almost two years has been working with a group of the satellite mini-schools in an effort to help them develop clearer objectives, stronger programs, and closer ties to each other.

But, at the moment, it appears that the Haaren-style mini-school complex enjoys a more assured future. In Haaren's case, and in the cases of the schools now requesting help in adopting the Haaren model, the decision to reform educational programs and the school structure is the responsibility of the school principal and his staff. The decision thus amounts to a total school commitment to reform. Providing that planning and implementation are effective, it is a step that will be difficult to reverse. And, because it is a local commitment, it is less likely to be affected by

changes in leadership at the district or Board of Education levels.

Perhaps more important, the growing interest in adopting the mini-school complex model, at least in New York, represents a dawning awareness among urban educators that piecemeal solutions are not enough if their schools are to meet today's challenges. What is needed, they are beginning to realize, is a total restructuring of the school, from its curriculum to its organizational patterns to the ways in which it is managed, all based on sound planning.

Given that new awareness and the continuing efforts of individual school principals and staffs, the school system leadership, and catalytic agents like the Urban Coalition and the business community, it seems likely that the mini-school complex not only will survive but well may play a major role in the urban education of the future.

The restructuring of a school to accommodate new programs and new teaching methods is at best a difficult process; the possibilities for error are legion. To help educators and others involved in future school reform to succeed and to avoid the pitfalls along the way, the following is offered as a how-to-do-it guide, based largely on the experience of the New York Urban Coalition Education Program and, to a limited extent, on what is known about experiences with other reform programs.

In putting together this handbook, the author and his sources do not suggest that they have learned everything there is to be known about the process of school change. The answers are not all in. And, just as existing mini-schools and mini-school complexes continue to undergo changes in structure, so will the processes of effecting change be altered as experience produces new knowledge and insights.

The handbook is designed specifically for those interested in adopting the mini-school pattern as their answer to school reform. At the same time, however, it should be of interest and value to those exploring other avenues for the restructuring of their schools.

Finally, the handbook is premised on the conviction of its developers—the author and the staff of the Urban Co-

# RESTRUCTURING YOUR SCHOOL: A HANDBOOK

## PART I

alition's Education Program—that piecemeal approaches to school reform ultimately are destined for failure. Only comprehensive reform, involving the total replanning and restructuring of the school—e.g.: conversion of a traditional school structure into a mini-school complex—is likely to succeed. And it is only such comprehensive approaches to reform that are advocated here.

# IDENTIFYING YOUR PROBLEMS.

## STEP

# 1

To cite the obvious, the first and most critical step in reforming a school is to clearly identify the problems that make reform seem necessary. The task is more complicated than the simple process of listing your school's symptoms—poor reading scores, behavioral problems, truancy, a high drop-out rate, violence, drug use, and the like. What is needed is a clear understanding of the problems that give rise to the symptoms and to what extent the school's existing organization, programs, and personnel may be problems in themselves. In many schools, for example, class schedules are such that teachers who should be planning cooperatively have no time to meet for that purpose. In program areas, students seldom find their studies relevant to real-life problems.

In other words, it is necessary to obtain an accurate

picture of all aspects of your school's current situation. To do so, it will be necessary to develop both individual and group profiles of your students, identifying not only the student's academic standing and capabilities but his or her personal objectives and socioeconomic and ethnic background. (Guidelines to the development of student—and staff—profiles are offered in Part Two of this handbook.) Similarly, there is a need to evaluate the total school staff (not only the teaching faculty) in terms of who is holding what job and what each individual has to offer in terms of personal interests and strengths. Some guidance counselors, for example, are better equipped to deal with student problems while others are better at career counseling.

At the same time, there needs to be an evaluation or profile of the school's programs. Is the curriculum an integrated one in which there is continuity from grade level to grade level and in which courses complement each other? Are you operating a number of programs—in remedial reading, for example—that have identical objectives, duplicate each other, and involve waste? Are program goals or objectives both clear and reasonable? Are those involved in agreement as to those objectives? Are your programs in such areas as attendance, counseling, remedial reading actually achieving their objectives?

Then, it will be necessary to take a close look at the school's organization and its management. How are decisions made? Are there policy constraints that stand in the way of more effective programs or procedures? Can you see a relationship between your existing organizational patterns and what you perceive to be the school's problems?

It should be pointed out here that it is highly possible for an administrator to consider his school to be well organized when, in actuality, there is little or no communication between administration, middle management, and the staff. As this suggests, it is difficult for a school staff to effectively assess its own organizational and managerial structures. Accordingly, it may be desirable to seek outside help in the person of a professional management consultant or a university specialist in the field to assist in the evaluation process. (Possible sources of such outside assistance are suggested under Step Two.)

In fact, outside opinion may be a valuable way to lend objectivity to all phases of the self-evaluation process. Accordingly, it may be advisable at one or more stages in the process to invite administrators or key staff personnel from another school, preferably one that has experienced a reform project, to take an unbiased look at your current operations.

## EDUCATING YOURSELF

# STEP 2

Once the problems have been identified, the question then becomes one of identifying the possible solutions and sources of information about them. If the initiative is at the teacher level, the first step is to check with the department chairman or assistant principal for whatever information he may have about alternative programs and school reform. From there, the trail will lead to the principal's office and thence to the offices of the local board of education.

Most large school systems have specialized offices at the headquarters level that should be in a position to provide information about existing school reform programs. In

New York City, for example, a local high school would be well advised to check with the Office of High Schools, the Office of School Planning and Research, the Bureau of Educational Research, the Learning Cooperative, and the Division of Educational Planning and Support.

At the same time, there are extensive resources outside the school system that should be tapped. Among them are the local and regional schools of education, many of which have faculty and specialized libraries that can offer information on and assistance in the process of school reform. At Indiana University in Bloomington, for example, the Educational Alternatives Project of the School of Education publishes an occasional newsletter and has issued an international directory of alternative public schools.<sup>1</sup> Similarly, the Center for New Schools in Chicago offers leads to information on existing alternative programs.<sup>2</sup>

Resources also may be available through the machinery of your local teacher union or association. Both the American Federation of Teachers and the National Education Association are actively interested in school reform and, in some cases, have published materials available.<sup>3</sup>

Meanwhile, don't overlook the corporate world. Many of the nation's major corporations are deeply involved in

education. Some operate highly innovative programs for the training and retraining of their own personnel. Others have supported innovation and reform in the school system through the provision of funds, materials and equipment, or managerial expertise. Generally speaking, corporate help will be available only through headquarters offices. In some cases, however, major divisions or regional offices may be able to provide assistance. Corporate help may take the form of information on their own educational and training programs, leads to reform programs in the schools that have enjoyed corporate support, and/or assistance in your school's self evaluation, particularly in the areas of organization and management.

Then, there are a series of private foundations interested in and actively supporting school reform programs. An obvious example is the Ford Foundation, which has been active in the field for years and which recently published a report on alternative programs entitled "Matters of Choice."<sup>4</sup> Another is the Institute for the Development of Educational Activities (I/D/E/A), supported by the Kettering Foundation. But don't overlook the smaller foundations. A number of small, community-oriented foundations in cities like New York, Cleveland, and Hartford, Connecticut, are involved in local educational reform programs and relatively well informed on the subject.

Similarly, there are organizations like the New York Urban Coalition<sup>5</sup>, involved in programs to upgrade all aspects of urban life, including education. More specialized are organizations like New York's Public Education Association<sup>6</sup>, which has counterparts in some other cities, and New York's Economic Development Council, a cooperative corporate effort to aid the cities and their educational systems.

Finally, look to the literature. Check your local public library and, if there is one, your school system's professional library for appropriate publications. Don't miss such recent books as Mario Fantini's "Public Schools of Choice."<sup>7</sup> Tap into ERIC (the federally supported Educational Research Information Clearinghouse system) for the latest bibliography in your area of concern.<sup>8</sup>

<sup>5</sup> Educational Alternatives Project, School of Education, Room 328, Indiana University, Bloomington, Indiana 47401.

<sup>6</sup> Center for New Schools, 431 South Dearborn Street, Suite 1537, Chicago, Illinois 60605.

<sup>7</sup> Robert Snider  
Instructional and Professional Development Division  
National Education Association  
1201 16th Street, N.W.  
Washington, D.C. 20036 (202) 833-4337

Department of Research  
American Federation of Teachers, AFL-CIO  
1012 14th Street, N.W.  
Washington, D.C. 20036

*A National Design for the High School*, American Federation of Teachers 1973. Single copy \$ .50, 25 copies, \$.25 each.

<sup>8</sup> *Matters of Choice*, Office of Reports, The Ford Foundation, 320 East 43rd Street, New York, New York 10017, free.

<sup>9</sup> Education Program, The New York Urban Coalition, 55 Fifth Avenue, New York, New York 10003.

<sup>6</sup> Public Education Association    Economic Development Council  
20 West 40th Street                    230 Park Avenue  
New York, New York 10018        New York, New York 10017  
(212) 354-6100                            (212) 684-2300

<sup>7</sup> Fantini, Mario, *Public Schools of Choice: A Plan for the Reform of American Education*. New York, Simon and Schuster. \$8.95 hardcover.

<sup>8</sup> The ERIC system is a nationwide complex of research libraries, most located on university campuses. Generally, they are organized according to levels of education or specialized programs. No ERIC library specializes in alternative schools nor does any one of them store all available information on the subject. For information on which libraries have alternative-program information at appropriate school levels, contact Central ERIC, Office of Utilization and Resources, National Institute of Education, Washington, D.C. 20208, (202) 254-6050.



# ANALYZING THE DATA.

## STEP 3

Once you have acquired information on programs that ostensibly are relevant to your problems, it then becomes necessary to evaluate the data from a number of vantage points. The first and most obvious is to determine whether the original program was a success or failure. If success was claimed by the sponsors, has it been documented? Was there evaluation of the program and, if so, are the results available in documented form? The lack of such evaluation and documentation in some cases may not rule out further investigation and consideration for your situation. But it should cause you to proceed with extreme caution.

Successful programs or those that seem to hold promise for success then must be evaluated in terms of your own

situation. In effect, there must be a careful matchup to determine whether the available—and viable—alternatives tally with the set of priorities developed during your own problem-identification effort (Step One).

Finally, any reform under active consideration must be evaluated in terms of its potential effect on the total operation of your school. It is essential to understand and deal with the fact that change or reform in any one aspect of your school program or operation will have an inevitable impact on all other aspects. (For a valuable discussion of this phenomenon, see Chapters Six, Seven, and Eight of Seymour B. Sarason's *The Culture of School and the Problem of Change*.)

Accordingly it may be helpful to set up a chart or grid on which the impact of any reform can be weighed against such factors as overall costs of operation, ease of implementation, the existing decision-making process, curriculum and teaching patterns, the physical layout of the school, technological capacities, overall objectives, staff strengths and weaknesses, and the availability of outside resources.

Allyn and Bacon, Inc., 470 Atlantic Avenue, Boston, Massachusetts 02210.

# REACHING THE DECISION

## STEP

# 4

The process of reaching a decision to adopt a reform or series of reforms for a school is, in effect, the first step of a formal planning process. As such, its effectiveness depends on the involvement of the total school community, so that, once adopted, the reform(s) will have the support and cooperation of all concerned.

This means that the proposed reform or, if such is the case, a series of optional reforms, must be presented to the administration, staff members (both professional and

paraprofessional) and their union representatives, students, and parents in such a way that each group clearly understands the potential impact of the proposed changes on their own situations. This effort probably should take place in a series of meetings held by the planning committee for the various groups.

At the same time, it must be recognized that the proposed reforms will need the concurrence and/or support of individuals and agencies outside the school itself. These include the central board of education, the superintendent of schools, appropriate deputy or assistant superintendents, the community school board, if any, the local teacher union or association, potential foundation or corporate supporters, and, in some cases, the principals of "feeder" schools whose graduates will be enrolled in your building.

While it may not be necessary to involve these outside groups in your decision-making sessions, it is essential that they be kept informed of your plans and progress. Accordingly, an information system will be required through which regular progress reports may be disseminated. The key to the system is the development of a mailing list structured to insure that all key individuals, offices, and agencies are plugged into the system. (See "The Information Factor" in Part Two of this handbook.)

Involvement of the total school community in the decision-making process does not suggest anarchy or veto power for any one individual or group. Students, for example, will be informed, their ideas and reactions will be solicited and, where appropriate, adopted as part of the plan. However, as in any managerial situation, the ultimate decision must rest in one place. In a school, that will be the principal's office. But hopefully, the decision will be made with the assistance of a small planning group representing all elements of the school community. (See Step Five.)

Following the informational meetings, the reactions of each group—particularly the teachers—reacts negatively, it is likely that the proposal will be unworkable and should be sent back to the drawing board. Experience indicates that, when it comes to school reform, teachers are "the primary constituency." While the new program may be designed to meet the expressed needs of students or demands of parents or the outside community, it is unlikely to succeed if the staff does not feel comfortable with it or competent to teach in the new patterns involved.

A final and critical point: the decision must include a commitment to the implementation of the reform and its various elements within the confines of a predetermined time schedule. Without a commitment to timing, there really is no decision.

## GETTING THE GREEN LIGHT

# STEP 5

Once the decision to institute reform has been made, most schools will have to turn to higher authority for permission to proceed and, where necessary, additional resources necessary to support the planning process. And it may be necessary to seek support from outside the system, from corporations, governmental and private agencies, and the foundations.

To that end, the decision should be converted into two written documents, preferably by someone capable of producing clear, concise, and readable prose, free of pro-

fessional jargon. The first document will be short—no more than two pages in length—and will offer a concrete statement of the proposed reform, a statement understandable to even the most uninformed reader. If that statement cannot be made within the two-page limitation, it is likely that you actually don't know what you are attempting. Return to step four and re-examine your decision.

The second document will be more elaborate and lengthier—15 to 20 pages. It will set forth in detail what the reforms are intended to accomplish, the phases of its implementation, all components of the plan, the time schedule, and additional funding requirements, if any. It will be a working document, spelling out the operational plan, and will form the basis for formal proposals for approval and additional resources.

As will be seen later on, it is possible to conduct the planning process without additional funding through ingenuity in the use of staff time and through dedication on the part of planning team members. But, when and if extra funding is needed, it will be necessary to identify possible sources of support. Here, the local school board may be of assistance. Most have staff experts skilled in finding sources of support, such as government agencies, foundations, and organizations like the New York Urban Coalition.

Proposals then are submitted, negotiated, and revised if necessary. If and when they are approved, a formal written agreement between the school and the school board or district should be drafted and signed. The agreement, based on the two-page document cited above, will commit both parties to the project and spell out the resources of both parties to be employed in the planning, implementation, and evaluation of the project.

Similarly, written agreements should be concluded with sources of outside support. Such agreements will spell out the nature of the outside agency's involvement and the school's responsibilities, including financial reporting if funding is involved.

## Proposal—Suggested Outline

Title:

### Contents

- I. Introduction
  - a short 1-2 page overview to subject
- II. The Need
  - define your problem—be specific
  - what is happening now (locally) to resolve this problem
- III. What is the history of your organization (in relation to this need) and what are its qualifications to help resolve problem
  - include goals of your organization
  - history of related program development
  - success you've had
  - problems
  - costs
- IV. Proposal and Budget
  - what are you proposing to do
  - spell this out in careful steps
  - organization and personnel to carry out project
  - what is cost of each step and total cost
- V. Summary Statement and Anticipated Results
- VI. Appendices
  - A) Certification of organization and tax - exempt status
  - B) List of board of directors or trustees
  - C) Curricula vitae of key staff
  - D) Sample case history
  - E) Letters of support
  - F) Other supportive documentation
  - G) Last annual report

# INITIATING THE PLANNING PROCESS

## STEP 6

The process of planning for school reform requires machinery—an organization to which is delegated the responsibility for developing the plan and that has formal status, rather than an ad hoc position, in the school structure. The planning organization—it might be called the “school development team” (SDT)—should be small enough to be functional yet large enough to be representative. Ideally, it should represent all elements of the staff, the local community, and the student body and number somewhere between eight and ten people.

The SDT will be charged with the responsibility for converting the original proposals into a specific operational plan. In doing so, it will assist the principal in school-wide planning and, at the same time, become a vehicle by which all elements of the school constituency can channel their reactions, suggestions, and resources toward the planning objectives.

In setting up the SDT, it should be recognized that, once started, the planning process will be a continuous one. Accordingly, the SDT should be given an initial mandate covering at least enough time to carry out the plan to full implementation—a period of from two to five years, depending on the complexity of the project. And recognize, that even then, planning still will be required and that the school development team’s lifetime, therefore, probably should be indefinite.

This does not mean that SDT membership will be for an indefinite period. Membership should be rotated, possibly on a two-year basis, to maintain freshness of outlook. But the rotation should be staggered to insure continuity in the planning process.

Specifically, the SDT should assist in developing and reviewing proposals for reform or restructuring of the school. It should assist in designing and implementing

operational plans, perhaps its key function. And finally, it should monitor and evaluate project activities.

In developing the operational plan, the SDT in effect will be drawing a detailed map of the steps that must be taken to achieve project objectives. In doing so, it will provide answers to a series of key questions:

- What specific set of activities, taken altogether, will be required to attain project objectives?
- Who is responsible for each of these activities (including non-SDT members who have been delegated responsibility)? What resources have been committed to each activity?
- By what date must each activity be completed in order that later activities can be initiated?
- What are the implications of the failure to implement any one activity on schedule?
- Who is responsible for monitoring overall project activity to insure that all activities are completed on schedule or, failing that, the schedule is adjusted accordingly?

Care should be taken in the selection of SDT members to insure that, in addition to being representative, the group

includes individuals who are interested in the project and its success and who appear capable of working well in a task-oriented group. In addition, it must be recognized that, in their new assignments, members will be performing in unfamiliar roles. Most, if not all, will have little knowledge of or experience in the planning function. If they are to perform effectively, they will have to be trained.

The first step in training a planning group is to provide its members with a clear statement of the assignment—what they are going to do and why what they are going to do is important. The group then should be offered a thorough briefing—possibly extending over several sessions—in the nature and logic of the planning process. If specialized management tools—flow charts, the PERT system, GANTT charts—are to be employed, the SDT should receive specialized training in their use. Finally, the group ideally should run through one or more hypothetical planning projects to test their mastery of the process.

Few schools will have staff personnel equipped to conduct such a training program. It is possible but not probable that the local board of education can provide the necessary expertise. If not, assistance can be sought in the business community, which might be persuaded to provide help on a voluntary basis. Or the services of a university-based

management expert might be obtained. Failing all that, consideration should be given to the hiring of a management consultant, preferably one with an interest in education and school operations.

Finally, remember that a critical function of the planning group will be informational. The school community and its broader outside constituency must be kept informed of the SDT's efforts, decisions, and progress if the ultimate plan is to win acceptance, cooperation, and support. Accordingly, the group at the onset must reach agreement on a reporting system that may include meetings, formal reports, bulletins, or a combination thereof and that functions on a predetermined schedule of frequency.

## SETTING YOUR OBJECTIVES

STEP

7

Obviously, the ultimate objective of any school, no matter how elaborately stated, is the education of its students. If the school is successful in meeting that objective, there presumably would be no need for reform or for the planning process. But the fact is that few schools—even those enjoying presumably ideal conditions in the affluent suburbs—are totally successful with all of their students and, therefore, without a need to improve. And no school is immune to the pressure of changes in the world around it and the need to adapt to those changes.

In any reform project, then, it is the job of the planning group to look at the overall objective in terms of the problems identified in Step One. What specifically needs to be done to solve the problems—what are the goals that must be achieved if the objective is to be met?

The first goals will deal with students: Is there a need to improve achievement levels? If so, in what subject areas and to what extent? Is there a need to improve student attitudes and behavior, as reflected in truancy and dropout rates, attendance patterns, disruptive behavior, vandalism, drug use?

Attention then must be turned to the learning environment. Does the school have the resources in curriculum, teaching and guidance personnel, materials, and equip-



ment, to achieve the student goals already established? If not, goals will have to be set for these areas. If, for example, student goals call for the creation of smaller learning environments, on the mini-school pattern, individualized instruction, and interdisciplinary programs, goals probably will have to be set for the appropriate retraining of teachers, development of new curriculum, and the production or acquisition of new instructional materials and equipment. Similarly, if the new educational programs call for new patterns of student groupings, goals probably will be required for the rearrangement and renovation of the physical plant.

Next, the school's organizational structure and managerial arrangements must be examined to determine if they are adequate in the light of the new programs and teaching patterns. If, for example, interdisciplinary programs are called for, it probably will be necessary to assign new roles to the chairmen or assistant principals in charge of traditional academic departments. If mini-schools are in the plan, it will be necessary to establish an administrative structure for them. If continuing change is contemplated (as it should be) it will be necessary to establish machinery by which it is accomplished in an effective and orderly manner.

Finally, there should be a concern with the change process

itself. Are all those involved aware of the changes being proposed and of the effect of the changes on their own situation? Are they prepared to accept the changes and to help implement them? Do they understand and accept the new roles they must fulfill? If not, a school-wide program to develop a consciousness of the change process is called for.

Once the goals are established, it is necessary to identify the specific steps—"activities" to the planning specialists—required to achieve them. If, for example, the goal is to improve attendance, it will be necessary to generate an across-the-board improvement in student attitudes toward school. One step in that direction might be an increase in the number of out-of-class activities attractive to students, but still relevant to the educational program.

Activities like this can be broken down into specific tasks, responsibility for which will be assigned to specific staff members when the plan is implemented. Ideally, the tasks involved in each activity should be charted sequentially and a predetermined deadline assigned for their completion. If the knowledge or talent required to carry out a specific task is not available within the staff, it probably will be necessary to seek help from the school board, local universities, or other outside sources, to assist in its completion or to train staff personnel for that purpose.

# THE WRITTEN PLAN

## STEP

# 8

Once the objective-setting process is complete, it then is necessary to translate the results into a written document of 20 to 30 pages, clearly stating the objectives, goals, activities, and steps involved in the total plan. The completed document ought to provide a very precise picture of what will have been accomplished a year or even two years after the plan has been adopted and the implementation process begun.

If the planning group has the capability to handle such managerial tools as Gantt and PERT charts, a flow chart should be developed to provide a graphic and readily understandable road map for the project. In addition, charts should be developed showing the school's existing organizational structure and the structure that will apply after implementation of the plan. If comparison of the two charts does not indicate significant organizational change, the plan probably will not succeed. (New programs and new structure require new organizational arrangements.) Return to Step Seven and re-examine your organizational and managerial goals.

The written plan should be prepared by a member of the School Development Team who: 1) has demonstrated writing ability, 2) has been interested and involved in the planning process from its outset, 3) preferably has acted as a recorder, transcribing the group's decisions about processes, procedures, and formats during the planning process or was responsible for reporting back to the school community on planning progress and decisions, and 4) sees an advantage to himself in the success of the plan.

The document initially should be prepared in draft form and submitted to the full planning group for approval and revision before a final version is drawn up for adoption.

# ADOPTING THE PLAN

## STEP 9

Adoption of the completed plan is a three-stage process—acceptance by the school community, revision where necessary to insure community acceptance, and only then submission to and approval by higher authorities.

The acceptance stage should be an extension of an

informational program started at the outset of planning, under which the community has been kept informed of progress and of all major decisions along the way. Once the written plan is complete, it should be made available to everyone in the administration, staff, student body, and local community. This does not mean that there need be the expense and effort to distribute copies of the full document to every individual involved. But copies should be available for inspection in the principal's office, faculty lounge, the school library, and through key organizations and agencies in the community.

Care should be taken that all concerned are notified that the plan is available for study and sufficient time should be provided for interested individuals to avail themselves of the opportunity. And an effort should be made to publish highlights of the plan either in the local newspaper or in a widely distributed special newsletter or bulletin.

Once the community has had the opportunity to study the written plan, a meeting or meetings should be called at which the full planning group offers a verbal description of the plan and opens the floor to a full discussion of the details. Such meetings are most critical for the faculty and staff, who will have to implement the plan. It may be advisable to hold separate meetings for the students, who will participate in the transition. And, depending on the

## BUDGETING BY OBJECTIVES: A SAMPLE

**OBJECTIVE: I.** Establish in-service training program for mini-school administrators and teachers.

Completion date	Activities	Responsible Person/ Staff Line	Manpower Category	Man Hours Per Act'y	Cost Per Man Hour	Cost Per Activity	Cost Per Objective	Cumulative Cost
12/74	End of year planning sessions for development of objectives, goals, activities, tasks	Principal	FT	180	20.73	3,731		
		Assist. Princ./Trg.	FT	180	14.35	3,583		
		Asst. Princ./Adm.	PT	180	12.38	2,228		
		Librarian	FT	120	9.57	1,148		
		Assist. Princ./Curriculum	FT	180	11.48	2,066		
		Assist. Princ./ Learning Environment	FT	180	11.40	2,066		
						<u>13,822</u>		
	Recommended policy (and implement) to Board of Education Chancellor and Borough Superintendent	Principal	FT	150	20.73	3,109		
		Assist. Princ./Adm.	PT	16	12.28	198		
						<u>3,307</u>		
							\$17,129	17,129

**OBJECTIVE II** Train approximately 300 school personnel in mini-school restructuring management, administration and curriculum development

Completion date	Responsible Person/ Activities	Staff Line	Manpower Category	Man Hours Per Act'y	Cost Per Man Hour	Cost Per Activity	Cost Per Objective	Cumulative Cost
6/30/75	Interfacing between AP Training Director and AP Curriculum, regarding reporting and evaluation of training activities	AP Training	FT	90	14.35	1,291		
		AP Curriculum	FT	90	11.48	1,033		
						<u>2,324</u>		
	Interfacing of Total Training staff and consultants to plan and coordinate activities	AP Training	FT	FT	14.35	660		
		AP Curriculum	FT	FT	11.48	528		
						<u>1,188</u>		

(continued on next page)

Interfacing with school development Teams for on-going coordination of training activities at mini schools level	AP Training	FT	72	14.35	1,034	
	AP Curriculum	FT	135	11.48	1,550	
	AP Learning Environment	FT	112	11.48	1,285	
	MS Coordinators (4)	FT	120x4	9.57	<u>4,592</u>	(1,148x4)
Development, maintenance and coordination of all training programs including materials, people, resources, curriculum, etc.	AP Curriculum	FT	403	11.48	<u>4,626</u>	
					4,626	
Interfacing between AP Curriculum and individual training staff and consultants for supervision, reporting and evaluation	AP Curriculum	FT	90	11.48	1,033	
	Consultants				30,000	
	Universities				<u>96,000</u>	
					127,033	
Prepare and submit bi-weekly and quarterly analytical reports on status of programs vs. objectives to AP training	AP Curriculum	FT	62	11.48	<u>712</u>	
					712	
Carry out general and administrative support activities	AP Curriculum	FT	135	11.48	<u>1,550</u>	
					1,550	

\$145,894

\$163,023

Level of involvement and interest, it may be desirable to hold sessions for community groups.

It is essential, in conducting these informational meetings, to make sure that elements of the school's constituency clearly understand the plan and its implications for themselves. Formal votes may or may not be necessary, but it is critical that the planning team satisfy itself that no group is substantially opposed to the plan or any of its major elements and that every group understands the plan, is in general agreement, and is prepared to lend its unqualified support when it comes time for implementation.

Based on discussions at the informational meetings, revisions to the plan may be required to secure formal acceptance by faculty and staff or desirable to insure maximum support for its implementation. Such revisions should be made by the individuals who prepared the initial written plan and submitted to the full planning group for final adoption. At the same time, supporting documents such as requests for budget revisions or additional resources needed to implement the plan should be prepared for submission with the plan for approval by higher authorities. Similarly, revisions or appendices may be required if the document is to be used to seek financial assistance from foundations, government agencies, or other outside sources.

## IMPLEMENTING THE PLAN

# STEP 10

The new structure and new programs called for by the plan will mean new roles and new tasks for most if not all of the school staff. Accordingly, the first step in implementing the plan will be to retrain the staff so that each member is familiar with and comfortable in his or her new role and prepared to carry out the new responsibilities. To reverse the procedure and attempt to implement a new structure before your personnel are prepared for it is to court failure.

Separate training programs will be required for administrators, teachers, paraprofessionals, and perhaps clerical and other support personnel. And, within those categories, it probably will be necessary to develop further breakdowns in the program. The training of assistant principals, for example, will differ from that for mini-school coordinators. And streetworkers require a different program than that provided for teacher aides.

But, in assigning personnel to their programs, avoid any attempt to lock individuals into specific staff assignments. As training progresses, it can be expected that individual skills and traits will be found that will affect ultimate job assignments. Among teachers, for example, some may emerge as better equipped by background and attitude to work in a team or interdisciplinary setting while others may be more comfortable in a more traditional role. If, as is the case in some projects, coordinators are elected by the mini-school staff, some teachers may emerge as leaders in the eyes of their colleagues, win election as coordinators, and require further training to fulfill that role. In the case of streetworkers and guidance counselors, some may work better with college-bound students while others may be challenged by the need to help those with serious learning disabilities.

In an important sense, the training program will be an

extension of the learning process begun when the School Development Team first was organized. In addition to requiring new skills, staff members will be working out details of the operation of their respective mini-schools, administrative offices, or other school function.

Training programs can be conducted during after-school hours or over the summer. But it must be recognized that, in most cases, such a schedule will involve expense, since union contracts will require payment of teachers and others involved in the program. An alternative, proven feasible in at least one case in New York, is the imaginative scheduling of staff time so that training/planning sessions can be held regularly during school hours. (See "Scheduling Your Mini-School") And, given sufficient staff commitment and enthusiasm, it may be possible to stretch such sessions somewhat beyond the normal school closing hour without incurring union opposition.

Either way, the training process will take time—perhaps as much as six to nine months—and actual implementation should be scheduled accordingly. In fact, progress of the training effort should be monitored continuously, preferably by a subcommittee of the School Development Team. If, for any reason, any element of the training effort falls behind schedule, the implementation plan should be revised accordingly, and the revisions reported to the principal.

As in earlier project phases, the training program may require the assistance and support of people from outside the school. It may be possible to borrow from the expertise of principals and staff personnel from schools that have undergone similar restructuring projects. Or, it may be necessary to acquire help from local universities or educational consultants.

Outside help or not, it is critical to insure that the time devoted to your school's training/planning sessions is effectively employed. It is all too easy for a group of teachers (or any other group, for that matter) called together for planning purposes to drift into meaningless discussion of the *status quo* or to lose themselves in minutiae. Careful planning and effective leadership are required if the training effort is to be productive. For some particulars, see "Promoting Interaction and Growth" in Part II of this manual.

Once the training program, or appropriate phases of it, is complete, final job assignments are made and actual implementation begins. The schedule may call for simultaneous implementation of all phases of the plan or for a gradual, step-by-step approach. Either way, the SDT monitoring team must keep a close watch on progress to insure that implementation is effective and orderly and that unforeseen problems can be resolved as they occur.

## INSTITUTIONALIZING CHANGE

STEP

# 11

To effectively restructure a school is to set in motion a process of continuing change. Continuing change requires a mechanism for continuing planning. At the same time, it requires mechanisms for the continuous retraining of personnel affected by the changes and for the restructuring of the management systems and procedures that support and direct school operations.

If, as recommended earlier, you have employed a school development team to plan your project, the machinery for continued planning already exists. What now is required is that the SDT be accorded a formal and permanent status in the school structure. And, as suggested earlier, a system for rotating SDT membership should be established to insure both continuity of planning and freshness of input.



As a permanent and legitimate planning arm of the school, the SDT will continue to monitor programs (see Step Twelve) and, where improvement seems desirable, recommend appropriate changes. At the same time, it should function as a link between the school administration and the sources of new ideas, whether they come from within the school, from the local board of education, or from outside agencies.

In that role, the SDT will receive proposals for new programs or changes in structure and evaluate them in terms of existing operations and available resources. It then may approve or reject the proposals outright or suggest revisions. Once a proposal or revised proposal wins SDT approval, it is forwarded to the school's top administrative body—e.g. : the school cabinet—for final action.

The need for a continuing training effort again suggests the need for a formal and permanent mechanism responsible for that function. That mechanism—which might be called the professional services center (PSC)—will be responsible not only for the retraining of teachers and other staff personnel but for the development of curriculum to meet the needs of the school's new programs.

The curriculum-development effort can and should be an integral part of the training process. (That effort, incidentally, probably should not begin until the new

organizational structure is in place and functioning. The curriculum should take advantage of the new environment, if the new environment is not in place curriculum developed outside it is not likely to "take.") As was suggested earlier, "planning equals training." The PSC should be so organized that it provides individual teachers or teacher teams from a mini-school or similar new unit with the means and materials with which to develop new curriculum.

It should be a center where, to the extent possible, all available information and guidance needed to develop or introduce new programs, teaching techniques, and curriculum, is at the staff's disposal. It should provide or offer access to the hardware necessary to develop and utilize software for audiovisual equipment, television, and other new teaching technology.

The center also should be in a position to tap outside resources for both the curriculum development and teacher-training efforts. If, for example, help is needed in developing new remedial reading programs and the training of teachers in their use, the center might bring in consultants from a local university. But, to lend legitimacy to and facilitate acceptance of the consultants' work, care should be taken to insure that they work through the PSC and its director rather than deal independently with individual teachers.

Finally, the center should be designed as a place where teachers and other staff members will gravitate when in need of information and where they will gather to share their experience and discuss new teaching techniques and curriculum. Accordingly, the center should be conveniently located and comfortably and attractively furnished.

Existence of the center, of course, will not obviate the need for other teacher training opportunities. Teachers will continue to require or desire advanced training in a traditional university setting or want to take advantage of special programs offered by the local board of education, state and federal education agencies, private industry, or agencies like the Education Program of the New York Urban Coalition. The PSC, however, can and should act as clearinghouse of information on such opportunities and assist interested teachers in availing themselves of them.

A possible mechanism for restructuring or retuning management structures and procedures may be found in what one New York school calls its management development office. Headed by an assistant principal for management, development, and planning, the office concerns itself with budget; inventory control; studies of total school resources in personnel, equipment, and materials; the development and maintenance of management manuals; systems studies of other school units, and a

series of other activities affecting day-to-day management of school operations.

The MDO is organized to make effective use of outside talent—such as business loanees—in its operations. Working through the office, the loanees have a legitimate channel through which to contribute their knowledge to the solution of the school's managerial problems.

# EVALUATING THE RESULTS

## STEP 12

Without a continuous process of measurement and evaluation of progress and feedback of the findings, neither the continuous planning effort nor the retraining program are likely to be effective. As suggested earlier, the evaluation effort should be assigned to a subcommittee of the School Development Team.

The subcommittee will monitor all school programs and check their progress against the operational plan, reporting back periodically to the full SDT. Where progress does not measure up to intentions and schedules as set forth in the

plan, the SDT will consider and recommend changes in the plan, the schedule, or both.

In carrying out its functions, the subcommittee will not be a judgement agent. It will not be empowered to evaluate the performance of individual teachers or to involve itself in the process of granting teacher tenure or promotions or in recommending suspension or dismissal of teachers who fail to perform. Rather, its role will be that of "a supportive set of eyes," empowered to look at the overall project and its component parts and, where necessary or desirable, recommend structural, programmatic, or policy changes.

The subcommittee will—and should be—an in-house entity, made up of school personnel, and carrying out the process of continuous evaluation. But remember that, as staff people, its members may be too close to the project to recognize all of its problems. It therefore may be advisable to periodically call in an outside team of evaluators from other schools, board of education headquarters, a local university, or an educational or management consulting firm. These outside evaluators should have the advantage of distance from the project and the ability to identify problems not perceived internally and produce suggestions and proposals that might not have been generated by an in-house team.

## PART II: DEALING WITH THE NITTY-GRITTY

Beyond the major questions dealt with in the first half of this handbook, the process of restructuring a school will require the ability to deal with a series of procedures and techniques for both implementation and operation—the “nitty-gritty” of school reform. Some “how-to” suggestions, again based largely on the Urban Coalition experience, follow.

### PREPARING YOUR BUDGET

Both the planning effort involved in restructuring a school and operation of the resulting new programs will involve money. This does not necessarily mean that *more* money will be required, simply that money is a key resource in the planning process or in school operation and its use must be planned as carefully as any other aspect of the project.

In the initial planning effort, the major investment will be in time—time spent by administrators, teachers, and others in developing goals, objectives, programs, and implementation plans. It is axiomatic that “time is money” and it has been estimated that anywhere from six to nine months of planning time is required before implementation

of any plan to totally restructure a school. During this period, there should be intensive involvement on the part of a planning group of other staff members in special projects related to the planning effort, and periodic involvement of the total faculty.

If the time involved in these commitments must be spent outside normal school hours, collective bargaining agreements may require that the participants receive additional pay. The planning budget will have to be structured accordingly. However, experience indicates that, by imaginative school scheduling, time can be provided during the normal day for the planning process and no additional salary outlays will be required. (See “Scheduling the Mini-School.”)

But, as suggested earlier, in many cases it will be necessary to call in an outside consultant to help the planning team acquire the requisite skills to carry out its function. Ideally, such a training effort will include at least one intensive two-or-three-day session outside the school. And, towards the end of the planning period, it may be desirable to conduct a retreat for the full staff at which the planning group presents its proposals for discussion, revision, and approval. In the process, implementation is set in motion

Consulting services and outside meetings and retreats will involve costs normally not provided for in a school budget. In some cases, discretionary funds allocated to school principals by the school system have been used to cover such costs. But if such funds are not available, special funding from the school system or outside sources such as a foundation may be required.

Similarly, it must be recognized that the planning effort will involve indirect costs—postage for the informational program, telephones, heating and lighting if building space is used after normal school hours, stationery, duplicating costs, and secretarial services. But, again, a reallocation of available resources may make it possible to cover these costs without the need for special funding.

Whether or not additional funding is required, development of a budget for the initial planning process is highly desirable. Only through the budget-making effort will it be possible to determine what resources are to be devoted to the planning effort and how those allocations will affect other school activities.

Preparing the planning budget is a relatively straightforward process. It is a matter of identifying each step in the planning process, the schedule for each step, and the personnel and other resources required for its implement-

tion. For example, two staff members might be assigned to conduct an inventory of school resources and released from other duties for a total of sixteen hours a week for a two-month period to complete their assignment. They might require secretarial help for four hours a week over the same period. And there will be a need to provide the necessary stationery, telephones, and the like.

The budget for this activity then can be established by prorating the salaries of the staff members and secretarial help according to the time allocated and by estimating the indirect costs involved. The same procedure is followed for each activity scheduled for the duration of the planning effort. Then, on a month-by-month basis, the total planning budget is established.

A similar procedure is followed in establishing an operational budget. The primary difference is that, unlike the initial planning budget, the operational budget for a fully-implemented program will reflect repetitive activities and thus will show little month-to-month fluctuation in total outlays. But, if school restructuring is implemented gradually and new programs phased in on a step-by-step basis, the budgeting process will be more complicated. (See sample budget below).

The critical question in developing an operational budget

is whether the finished product offers a realistic picture of the costs of the school's programs. Schools traditionally have operated on a line budget in which allocations are categorized by codes covering such categories as "personnel services," "other-than-personnel services," "consumable supplies," and "equipment." The problem with the line-budget approach is that it is difficult, if not impossible, to identify the true costs of operating any one school program—remedial reading for example—by a simple budget analysis.

While system-wide and/or municipal budgeting procedures generally require the use of a line budget, management specialists argue that schools should supplement it by developing a program-based approach. Called the Program Planning Budget System (PPBS), the approach involves isolating the actual costs, including all the line-budget categories, of each program or activity in the school. PPBS not only offers a clearer picture of where the school's resources are expended but provides a far better base for decisions about the intelligent reallocation of resources to meet changing needs and changing programs.

## IDENTIFYING YOUR RESOURCES

It may be to belabor the obvious but, to restructure a school and its programs, it is essential to know beforehand

what already exists in terms of programs, personnel, equipment and materials, and finances. In other words, there must be a clear picture of the resources at your disposal. Obvious as the need may appear, it is a rare school that really knows where it stands in these terms. In most cases, therefore, schools undertaking a restructuring project will first have to conduct a thorough and detailed inventory of their total resources.

Developing an inventory is not unlike budgetmaking. The first step is to take the school's organizational chart and from it prepare a comprehensive listing of every position on the staff. A one-sentence description of each position is prepared, indicating job title, function, how the position is funded, and to whom that individual reports. The product will be a general inventory of school personnel. But the chances are it will not be complete—that up to 30 per cent of the people who actually have a role in the school will have been missed. Make sure that such people as school volunteers, business loanees, the security staff, and police and other outside-agency personnel assigned to the school are included.

Once the list is complete, recognize that job titles and descriptions do not reflect the fact that a social sciences teacher also is a human being with other interests and skills and with individual strengths and weaknesses in such areas

## ABC HIGH SCHOOL PLANNING BUDGET FISCAL YEAR 1974-75

### Training Program

#### I. SALARIES AND FRINGES (phasing in schedule)

SALARIES	JULY	AUG.	SEPT.	OCT.
1. Principal	2,708	2,708	2,708	2,708
2. Assist. Principal/Administration	1,231	1,213	1,213	1,213
3. Assist. Principal/Teacher Training	1,875	1,875		1,875
4. Librarian	1,250	1,250	1,250	1,250
5. Adm. Secretary to Principal	1,088	1,088	1,088	1,088
6. Assist. Principal/Curr. Development (at \$1500/mo × 12 mo)	1,500	1,500	1,500	1,500
7. Assist. Principal/Learning Environment (at \$1500/mo × 10 mo)	—	—	1,500	1,500
8. Assist. Librarian (at \$1000/mo × 8 mo)	—	—	—	—
9. 4 Coordinators (at \$1250/mo × 8 mo)	—	—	—	—
10. Secretary (at \$750/mo × 10 mo)	—	—	750	750

#### FRINGES (at 20%)

#### II. CONSULTANTS & CONTRACTS

Consultants General/Administration	167	167	167	167
Consultants In Service Training	167	167	167	167
Consultants Teachers Training	—	—	3,000	3,000
Consultants University Sub-Contracts	—	—	6,850	9,600
Evaluation and Documentation	—	1,000	1,000	1,000

NOV.	DEC.	JAN.	FEB.	MARCH	APRIL	MAY	JUNE	TOTALS
2,708	2,708	2,708	2,708	2,708	2,708	2,708	2,708	\$ 32,500
1,213	1,213	1,213	1,213	1,213	1,213	1,213	1,213	14,560
1,875	1,875	1,875	1,875	1,875	1,875	1,875	1,875	14,500
1,250	1,250	1,250	1,250	1,250	1,250	1,250	1,250	15,000
1,088	1,088	1,088	1,088	1,088	1,088	1,088	1,088	13,050
1,500	1,500	1,500	1,500	1,500	1,500	1,500	1,500	18,000
1,500	1,500	1,500	1,500	1,500	1,500	1,500	1,500	15,000
1,000	1,000	1,000	1,000	1,000	1,000	1,000	1,000	8,000
5,000	5,000	5,000	5,000	5,000	5,000	5,000	5,000	40,000
750	750	750	750	750	750	750	750	7,500

\$178,110

\$ 37,222

Sub Total Salaries & Fringes

\$215,332

167	167	167	167	167	167	167	167	\$ 2,000
167	167	167	167	167	167	167	167	2,000
3,000	3,000	3,000	3,000	3,000	3,000	3,000	3,000	30,000
9,600	9,600	9,600	9,600	9,600	9,600	9,600	9,600	93,250
1,000	1,000	1,000	1,000	1,000	1,000	1,000	1,000	11,000

Sub Total Consultants & Contracts

\$138,250





# ABC HIGH SCHOOL PLANNING BUDGET FISCAL YEAR 1974-75

## III. OTHER THAN PERSONNEL FUNDS

	JULY	AUG.	SEPT.	OCT.
Education Materials				
a) "Hardware"			3,000	
— Video/Tape				
— Audio Visuals				
— Curriculum				
b) "Software"				
(consumables)			500	500
— Teacher Resource				
Materials				
Training Manual	1,667	1,667	1,667	1,667
Publications	167	167	167	167
Dues & Subscriptions	500			
Equipment				
Travel & Conference		473	473	473

## IV. ALLOCATED GENERAL EXPENSE

### I. Allocated Expenses and Overhead

Telephone  
Electricity  
Postage  
Services

NOV.	DEC.	JAN.	FEB.	MARCH	APRIL	MAY	JUNE	TOTALS
2,000	—	3,000	—	—	—	—	—	\$ 8,000
500	500	500	500	500	500		500	<u>5,000</u>
							Educational Materials	\$ 13,000
1,667	1,667	1,667	1,667	1,667	1,667	1,667	1,667	20,000
167	167	167	167	167	167	167	167	2,000
—	—	500	—	—	—	—	—	1,000
—	1,000	—	—	500	—	—	—	1,500
473	—	473	473	473	473	473	473	<u>4,728</u>
							Sub Total Other Than Personnel Funds	\$ 42,228
							Total Direct Expenses	\$395,810
								<u>142,268</u>
							Total Operating Budget	<u>\$538,078</u>

146

**ABC HIGH SCHOOL  
BUDGET SUMMARY— Fiscal Year 1974-75**

**Training Program**

**I. SALARIES AND FRINGES**

Salaries	\$178,110	
Fringes (at 20%)	<u>37,222</u>	
Sub Total		\$215,332

**II. CONSULTANTS AND CONTRACTS**

Consultants for Administration	\$ 2,000	
Consultants Inservice Training	2,000	
Consultants Teachers Training	30,000	
Consultants University Subcontracts	93,250	
Evaluation and Documentation	<u>11,000</u>	
Sub Total		138,250

**III. OTHER THAN PERSONNEL COSTS, ADMINISTRATIVE AND GENERAL**

Training Manuals	\$ 20,000	
Dues & Subscriptions	1,000	
Educational Materials	13,000	
Publications	2,000	
Equipment	1,500	
Travel	<u>4,728</u>	
Sub Total		<u>42,228</u>
Total Direct Expenses		395,810

**IV. ALLOCATED GENERAL EXPENSES**

**TOTAL BUDGET**

<u>142,268</u>
<u><u>\$538,078</u></u>

as teacher-student relationships. Knowledge of these individual differences will help in the effort to employ your staff resources to the fullest potential. To identify these characteristics, questionnaires and/or interviews should be employed with everyone identified through the inventory.

The inventory also will identify the share of the school's budgetary resources spent on each position or function, the equipment and materials employed, and the supplies and services consumed. It then should be possible to evaluate the costs related to each position in terms of its effectiveness in meeting the objectives of the existing program and/or new objectives envisioned in a restructuring project.

At the same time, it should be possible to identify the total resources applied to the school's primary needs and objectives. If, for example, reading is a major problem, it should be possible to identify not only the total amount of the resources devoted to solving the problem but whether they are the proper resources and whether they are effectively applied.

The inventory also should extend to the availability of outside resources, whether from public and private agencies, corporations, or foundations. The question is not simply one of determining that financial or other support is

"out there" and presumably available to the school. It also is necessary to determine whether the school is organized to take advantage of outside help. This means that there must be a clear understanding of the type of assistance available from each outside source and whether and how such assistance might be applied in the school, and there is a need for administrative machinery to apply for the assistance, monitor its use, and report back to the outside source.

## DEVELOPING CURRICULUM

A major element in any effort to restructure a school along mini-school lines will be the development of new curricula designed to match mini-school themes and to provide activity-oriented programs that will attract and hold student interest. Experience suggests, however, that the curriculum development process should not begin until the school's new organizational structure is in place and has been operating for a semester or more.

This timetable reflects the fact that, ideally, the new curriculum for a mini-school should be developed by the teaching team that will be using it. But teachers who have been employed in the traditional educational setting are not accustomed to working as part of a team. Accordingly, time should be allowed to develop team consciousness in

the mini-school staff before asking it to turn its attention to the collective planning of curriculum.

Even then, the beginnings should be modest. The team might choose a small curricular activity such as a two-week interdisciplinary "mini-course" on a topic of compelling interest to the mini-school's student population. For example, the mini-course might deal with the ways in which health care is delivered in the surrounding community.

The team members would work together to determine how lessons in each of their subject areas might be tailored to the mini-course topic and how field trips, health fairs, and other activities might be programmed to supplement the classroom phases of the mini-course. The program need not take up the full school day; time still will be devoted to more traditional classroom activities.

With the mini-course experience under its belt, the team then should feel confident to undertake more ambitious efforts, such as a coordinated six-week program covering a broader topic. And, ultimately, the team should be ready to develop semester-long, interdisciplinary programs. The process should continue, step-by-step until a totally new mini-school curriculum has been developed. But it should not stop there. The student population and the community

inevitably will change and needs will change accordingly. Curriculum development to meet those needs can and should be a continuous process.

While the curriculum development effort should be carried out by the teaching team, it is likely that it will need support. Teachers are not necessarily curriculum specialists by either training or inclination. They very likely will need help from outside experts, possibly provided by the school's professional services center if such exists. If not, outside agencies from the universities or the community may be required.

Support also will be required through the availability of materials for incorporation into the new curricula. A vast amount of material in all of the media—print, film, and tape—that may be useful in mini-school curriculum development already is available. But, given their schedules and the sheer quantity of the new material, it is impossible for individual teachers or, for that matter, teacher teams, to keep up-to-date on what is available. This is particularly true in such areas as high-interest reading materials developed for students with limited vocabularies.

Given the situation, it seems desirable that someone, probably in the school's staff development center or teach-

ing center, should devote substantial time to searching the market place and alerting teacher teams to the availability of appropriate materials. Teachers also should be familiarized with the existence of curriculum clearinghouses such as the Council on Economic Education or the Open Doors project of New York's Economic Development Council.

Finally, in all curriculum development efforts, the teacher teams and their outside consultant, if any, should keep several key considerations in mind.

- Take into account the developmental age of the students the curriculum is designed to serve.
- Remember that, whatever its nature, the curriculum must prepare the student for work in the higher grades. Continuity without the sacrifice of mini-school individuality is the requirement.
- Remember that the new curriculum will be but part of the student's broader educational experience.
- And, finally, place greater stress on skills than on course content.

## IDENTIFYING YOUR CLIENTELE

Mini-School complexes and similar efforts at school reform are premised in large part on an attempt to

individualize and humanize the educational process. It follows that, to provide programs tailored to individual needs, it is necessary to identify and understand those needs. A thorough inventory of student abilities, achievement levels, and potential is essential.

An obvious tool in such an inventory is the administration of standardized achievement tests in such areas as reading and mathematics. But the standardized tests should be used with caution and with the understanding that they will not provide all the answers. The tests and their interpretation can be extremely complex—the California Achievement Test in reading, for example, attempts to profile student ability in 30 different skills—and to understand the findings may take the help of experts. Then, there are the unresolved arguments about the validity of existing tests when employed with minority-group students.

Experience suggests that the first step in the inventory should be an elementary analysis of each student, carried out during a 15- to 30-minute interview with a teacher or guidance counselor. Ideally, the interviewer should be a person with a proven ability to relate to students and their problems and skilled in the techniques of eliciting responses. The interview is intended to provide answers to a series of critical questions:

— The student's feelings about himself, the world, and school in general.

— His attitude toward his courses and their relevance to his own situation.

— His feelings about his own progress in each course.

— His level of ability in such skills as reading and mathematics.

— His general state of health, to determine whether problems exist that might interfere with his school performance:

— His personal problems and factors such as home conditions that may affect his attitudes and performance.

— His personal objectives: Does he have a career in mind? What are his hobbies and other special interests? Does he have a hero, a public figure in any field whom he admires and would like to emulate?

Obviously, many of these questions are highly personal in nature. Many if not most students, and particularly those with problems, will be unlikely to respond fully and frankly if the interviewer gives the impression he is prying into the student's personal affairs.

Accordingly, it will be necessary to develop rapport with the student, to convince him that the interviewer has a real concern for the student and his problems and is sincerely willing to help. Proven techniques for developing such

rapport are described in "The Counseling Function" section of this handbook.

Meanwhile, it is important to recognize that, particularly in the case of personal questions, answers may not be forthcoming in the course of a single interview. Time, patience, and understanding will be required before a full picture can be developed of each student's situation. It is often necessary to wait for clues that the student is ready to talk about his problems.

Questions about student skills and performance are less sensitive in nature and may pose fewer difficulties. In reading, for example, the student can be asked to read passages of varying levels of difficulty. This should provide at least a rule-of-thumb understanding of the level of reading material the student is equipped to handle. If severe reading difficulties are indicated, plans then should be made to administer specific diagnostic tests—including a search for possible physical causes—to determine the nature of the problem and possible remedial measures. Similar procedures can be followed in identifying the student's mathematical abilities.

But, even here, some students may balk at making a response, particularly if they are sensitive about their inability to perform. Again, it will be necessary to develop

rapport between interviewer and student before an adequate understanding of the student's situation can be achieved.

Student interviews should be repeated periodically during the year. They will provide information, along with that developed routinely through standardized tests and school performance records, that can be used to produce group profiles indicating student characteristics for a mini-school or for groups within a mini-school.

## DEVELOPING STUDENT PROGRAMS

Information developed in the student inventory will provide the basis for the development of educational programs for both individuals and groups. Program development, particularly at the intermediate and high school levels, should address itself to four basic objectives:

- Development of the student's basic skills—reading, mathematics, the ability to organize himself to complete assigned (or self-assigned) tasks.
- Value education, the student's ability to make moral or judgmental decisions based on what he has learned.
- The ability to make intelligent decisions about a career or vocation.

— The ability to relate himself and what he has learned to real-world situations.

The process becomes one of helping the individual to meet his own needs in terms of these objectives and, at the same time, helping him to work as a member of a group. It is, in other words, a process of achieving individualization of instruction within a group process.

As indicated earlier, program development will rely heavily on information produced by the student profiles. But it also is advisable to watch each student's performance and behavior for a week or more to determine how the individual acts in different types of relationships. It is important to identify the student who is a loner, at one extreme, and the student who cannot function without group support, at the other extreme.

It may be desirable to run a series of special group activities—party games, rap sessions—to help in identifying these characteristics. Then, in building programs, attempt to gradually develop each individual's ability to work well both in group situations and on his own. If, for example, a student is a "leaner," i.e., dependent on a group situation to function, his program should be designed so that he is encouraged to undertake at least one independent project during the semester. And, later on, the frequency of his independent assignments should be stepped up.



Decisions about student grouping also will be affected by the inventory of student skills. In reading, for example, students who are unable to read will form one group for purposes of reading instruction. The same thing will happen with those who are marginal readers and those who are good readers. And, a similar process will be followed in programming for instruction in mathematics.

In meeting the career education objective, the effort will be to insure that each student is aware of the options open to him. This applies not only to students who have no career goals but to those who assume that their objectives should be college but have not explored other alternatives. The curriculum, particularly in English and social studies, can be employed to help expose students to the alternatives and to the process of intelligently deciding between them. But, particularly with students of 14 or over, it may be desirable to program a series of field trips that will expose them to the realities of work in a variety of careers and/or vocations. For some, the process might include a cooperative program in which their time is shared between school and an actual, paying job.

The total program should be built around all four of the objectives outlined earlier and should have specific goals in each area—i.e., a checklist of 15 or more specific accomplishments—against which progress can be checked

periodically. And the program should be developed around a *team* of teachers, taking advantage of the skills, interests, and strengths identified in the faculty profile. (See "Identifying Your Resources.")

## SCHEDULING THE MINI-SCHOOL

Once student program objectives have been established, it is necessary to organize the school's staff, space, and available time in such a way as to meet the objectives. Given the complexity of programming suggested in the preceding section, a key objective of this scheduling process must be the provision of maximum flexibility. Consideration must be given to such factors as the desire of most teachers to conduct basic skills courses early in the day, when both teachers and students presumably are more alert. And, most important if the mini-school is to operate effectively, time must be made available in the schedule so that the teaching team can meet regularly for planning purposes.

An innovative scheduling system that appears to meet all these requirements in a highly satisfactory fashion has been worked out at an intermediate school in the Bronx. The school, which enrolls about 1,200 students, is divided

into three sub-schools of about 400 each and a special sub-school for retarded students enrolling about 80. Each grade in each of the regular sub-schools has about 100 students and a teaching team of four—covering language arts, social studies, mathematics, and science. Other subject areas—foreign languages, art, music, physical education—are covered by non-team teachers.

The school operates on a seven-period-a-day, five-day week. Of the 35-period total, teachers in the team each must cover a total of 22 periods of instruction. The balance of student's day is taken up with "outside" activities: instruction in foreign languages, art or music, lunch periods, physical education, and shop courses. The result is that team teachers all have 13 free periods a week, some of which must be devoted to such duties as lunchroom supervision, maintaining student records, and the like. But, according to the school's administrators, it usually is possible to find at least eight hours a week during which the team can be brought together for planning purposes.

The secret lies in the scheduling of the "outside" activities in such a way that all four teachers in any one team are teaching at the same time and free at the same time. This means that the outside activities must be scheduled first on a schoolwide basis. Only then are the schedules

set, one at a time, for each sub-school. (See sample sub-school schedule below.)\*

In addition to providing time for teacher planning, the scheduling approach offers greater flexibility in programming. The sub-school teams each work in their own area of the school and, since they are teaching at the same time, can easily organize interdisciplinary programs and/or vary the size of student groupings for different activities. It is possible, according to the administration, to make large-scale changes in sub-school schedules in as little as two hours without significant impact on other school activities.

The approach is not without some drawbacks. It rules out the scheduling of "honors" courses in specific subjects, although sub-school groupings on an achievement basis still are possible. The last team to be involved in the scheduling process is left with few options in terms of the time of day their teaching hours are scheduled. But that handicap can be rotated between teams on a semester-to-semester basis. And other trade-offs are possible—e.g.: better teaching facilities for less desirable hours. The key is negotiation, complaints will be avoided if the teachers are kept apprised of the scheduler's problems and the fact that he cannot please everyone.

# Model School Schedule

	Monday	Tuesday	Wednesday	Thursday	Friday
1	Language Arts Science	Social Studies Math			
2	Social Studies Math	Science Language Arts			
3	GYM	Spanish	SHOP	Spanish	Music
4		Art		Language Arts Science	Social Studies Math
5			LUNCH		
6	Science Language Arts	Math Social Studies			
7	Math Social Studies	Language Arts Science			
8	Spanish	Music	Spanish	Art	Language Arts Science
					Social Studies Math

4 teachers program would look like this

1.	Subject	Subject	Subject	Subject	Subject
2.	Subject	Subject	Subject	Subject	Subject
3.	Prep	Prep	Prep	Prep	Prep
4.	Prep	Prep	Prep	Subject	Prep
5.	E	U	N	C	H
6.	Subject	Subject	Subject	Subject	Subject
7.	Subject	Subject	Subject	Subject	Subject
8.	Prep	Prep	Prep	Prep	Prep

1 A second group of 4 classes and teachers would be programmed into academic areas for periods 3, 4, 7, 8 each day + 2 other periods Exploratory areas (Gym, Shop, Art, Music, etc.) would then be programmed for periods 1, 2, and 6 for these classes.

## PLANNING THE ENVIRONMENT

Mini-schools, with their small enrollments and team and interdisciplinary approaches to teaching, require a different physical environment than that found in a traditional schoolhouse. Space is needed to accommodate instruction for both small and large groups and for independent study. Each mini-school should have a "living room," lounge space in which students and teachers can relax — and interact — when not in class. Teachers will need work space both as individuals and as a planning group. And all of these facilities should reflect the individual character, goals, and objectives of each mini-school. They should be designed to provide as much warmth and amenity as funds and ingenuity permit.

The typical school building, including many erected in the last few years, meets none of these requirements. But experience nationwide indicates that existing facilities can be recycled and retextured to house new programs in a warm and stimulating environment. Walls, unless they are load-bearing, can be taken down and/or relocated to provide space for different-sized groupings. Or, if funds are too limited, imaginative use of bookcases, folding

screens, free-standing chalk or bulletin boards, and other moveable furniture and equipment can be used to achieve the same effect. Because mini-school space reduces circulation requirements, corridors can be converted into instructional, lounge, or study space.

Warmth can be achieved through the use of bright-colored paint. Carpeting, particularly in the lounge area, can soften the environment and dampen noise. Standard, ceiling-hung lighting can be replaced or augmented by table lamps or clip-on fixtures to soften the visual environment without sacrificing adequate work light, saving energy in the process. Plants, fish tanks, cages for hamsters or other small animals, can be introduced to bring living things into the school environment. And mini-school identity can be established through the selection of colors, the use of graphics, or murals or such techniques as the mounting of candid photos of the mini-school staff and student body on a corridor wall.

The need to plan a new physical environment offers an educational opportunity that should not be overlooked. For, to be fully effective, the planning process should involve both teachers, students, and community representatives in the effort to determine just what facilities and amenities are suitable to the character and objectives of their mini-school.

It is likely, however, that the teacher-student planning team will not have the expertise to convert its ideas into a physical plan. The school's art department may be in a position to help and should be contacted to determine whether it can provide the necessary design talent. If it cannot or if it seems desirable to supplement art department input with outside assistance, consider following the example of a number of schools that have obtained the help of a new breed of specialists in "participatory planning."

These represent a small but growing group of design professionals having a deep commitment to the principle of involving the "real clientele"—teachers, students, and the community—in the planning process. In schools, the client traditionally has been the school system and/or its planning office. The system, after consultation with the school principal and perhaps token involvement of a staff committee, usually hires an architect or interior space designer and hands him a program of requirements. The architect comes up with a design. It is approved by the school system. The work is carried out. And the real client—the school's staff and students—is left with a physical environment that may or may not meet its actual needs.

In contrast, the "young designers" regard themselves not as experts with "the answer" but as catalytic agents, pre-

pared to listen to the clientele and help them to make decisions about their new environment. Only then do the designers turn to the drafting boards. The process not only is more effective in producing a workable physical plant but has the effect of educating the client, giving him a new awareness of the built environment in which he lives and works. This is not to suggest that students and teachers emerge as professional planners or that they actually will design the environment. But they are part of the planning process and emerge with a new literacy, an understanding of the process and of the physical environment.<sup>2</sup>

Ideally, the involvement of the outside designer should be of sufficient duration that the process he sets in motion will become a continuous one. Depending on the size of the school, this will mean a commitment of from one to three years. The involvement will be intense at the outset and gradually taper off as school personnel become familiar with the process and committed to its continuation.

Practitioners of the participatory planning approach to school design argue that involvement of parents and other community members is critical. They offer a generally untapped resource in planning and in the solution of problems. If, for example, an involved parent happens to be an electrician, he might be teamed with a science teacher to plan the revamping of electrical services.

The key to the process is to persuade and educate the participants to think about the environment in both practical and creative terms. How, for example, does a given school activity affect environmental requirements? The educational effort may extend to role playing, in which participants act out a school activity in an effort to determine whether facilities such as chalk boards, cabinets, or sinks are properly planned to accommodate the activity.

The process need not result in major expenditures for renovation or rehabilitation. The new designers favor the imaginative use of already available or inexpensive equipment and materials. And they see no reason why students and teachers cannot "build" their own environment, provided union problems can be avoided. In one such project, for example, a lounge area was furnished largely with carpeted boxes, built by students, to provide seating. And students did all of the painting work, including a large mural.

To the extent that funding is required, it may be more a matter of reallocating available resources than of finding new money. If and when the community, educated by parents and others involved in the planning process, becomes convinced of the importance of a better school environment, ways probably can be found to divert funds from other activities to finance the desired improvements.

The following publications on school renovation, while out of print, should be available in research libraries.

Graves, Ben. E., "Modernization," reprinted from *Nation's Schools*, April, 1971.

"Challenge . . . a report suggesting how an old school can continue to serve youth if the educational program is the prime consideration," Research Council of the Great Cities Program for School Improvement, 1968:

"The Loft Building as a School House: A Study for the School District of Philadelphia," Murphy Levy Wurman, Architecture and Urban Planning, Philadelphia.

"Awards: Architectural Competition for the Modernization of Hyde Park High School, Chicago," Research Council of the Great Cities Program for School Improvement, 1966.

"Pittsburgh Design Study: The Wightman Elementary School," Research Council of the Great Cities Program for School Improvement, 1967.

"School Renewal, A Report Suggesting Ways That Any School System Might Approach a Total School Modernization Program," McLeod, Ferrara and Ensign, Architects.

Still available at \$2 per copy is a report, "Places and Things for Experimental Schools," from Educational Facilities Laboratories (EFL), 850 Third Avenue, New York, New York 10022, (212) 751-6214.

And a major report on school modernization, as yet untitled, is scheduled for publication by EFL. It will include a step-by-step guide to the renovation process.

A guide to available materials and programs for schools undertaking programs in environmental education as well as descriptions of a number of such programs already in operation can be found in a new book, entitled *Learning About the Built Environment*. The book was written by Dr. Aase Eriksen and Judith Messina of the University of Pennsylvania and published by The National Association of Elementary School Principals. Research and preparation were underwritten by EFL and the Rockefeller Family Fund.

## DEPLOYING YOUR STAFF

The key to effective utilization of a school staff, whether in a mini-school complex or other organizational setting, is the realization that the staff is comprised of individuals who have interests and skills beyond those indicated by in their subject-matter specialty. It is a mistake to assume that, simply because he or she holds the license, the biology teacher is the only staff member who can teach biology. The assumption makes even less sense in a mini-school situation, with its stress on an interdisciplinary approach to teaching.

It is necessary, then, to identify individual interests and skills and strengths and weaknesses among the staff (see "Identifying Your Resources") and to take advantage of them in assigning staff. Recognize that different teachers will function better in some teaching situations than in others. Identify these differences through observation and /or interviews with individual teachers.

Once a clear picture of teacher capabilities has been established, it is necessary to make sure that the best person is assigned to carry out each activity or program required to meet the mini-school's objectives. To make the necessary match-ups of talents and needs, prepare a chart listing each position and the functions involved and, to the extent possible, assign people to each position whose skills appear to tally most closely with the job requirements.

A similar process should be followed with paraprofessionals. And it should be recognized that, while they cannot replace teachers, paraprofessionals such as street-workers can make a valuable contribution to the teaching process. Like teachers, they have skills beyond those indicated by the job title, skills that should be exploited. Similarly, don't overlook the potential in community residents who may be willing, on a voluntary basis, to lend their knowledge and skills to the educational process.



In deploying all of your human resources—professional, paraprofessional, or volunteer—remember that the ultimate object is to match the best possible people to the needs of students, not simply to assign them a job title and a schedule of working hours.

## USING OUTSIDE RESOURCES

As suggested repeatedly in this book, a wide range of assistance is available from sources outside the system for schools attempting to restructure themselves. Public and private agencies, the corporate world, foundations, universities, communities, consultants all have resources and/or expertise that can be brought to bear on school problems. But such assistance cannot be obtained easily or automatically. Strategy is required if these resources are to be tapped and if they are to be put to optimum use.

In the first place, it is essential that the school know what it wants. What are the problems that cannot be solved internally and how can outside resources be employed to resolve them? The point here is that no agency is in a position to provide general financial support to the schools or to respond to "shopping-list" requests for materials or equipment. There are, in short, no "Santa

Clauses" out there. But they can and do respond to requests for the support of specific programs aimed at the solution of specific problems.

Secondly, it is mandatory that the school familiarize itself with the nature of possible sources of assistance. Different agencies, corporations, foundations, and university programs have different interests and resources. Identify those interests and make sure they tally with your needs before approaching any source of support. Make sure that your proposal for assistance—whether verbal or in writing—clearly identifies your problem as relating to the source's area(s) of interest.

If outside assistance is to involve the presence of a business loanee or a consultant in the school, it is important to recognize that such involvement can create problems. Outside "experts" often are regarded with suspicion and distrust by school staffs, who may feel the outsider's presence represents interference rather than assistance. Accordingly, it is essential to develop an effective strategy of machinery for intervention. Experience indicates that the most effective strategy is to have the outsider work through the established school machinery rather than work independently with staff members. A curriculum consultant, for example, should work through the person in charge of the school's teacher center or professional

development center. And business representatives might work through the school's management development office, if such exists, or through the principal's office. Only through such one-on-one partnerships can the outsider gain credibility and acceptance in the eyes of the staff.

## THE COUNSELING FUNCTION

By its very nature, the mini-school should be a place that initially should be more concerned with guidance for its students than with subject-matter content. Small enrollments and staff continuity should lend themselves to a level of intimacy that permits the teacher to understand the individual student and his problems and to help guide him in the effort to find solutions. The mini-school, in other words, should be a place where the emphasis is on guidance as a prerequisite to content. Its teachers should be counselors as well as instructors.

Time should be allocated in the mini-school program so that each student periodically can meet privately with a staff member to talk over his objectives, his progress in meeting them, and his feelings in general about school and about the world outside the school. None of this is to

suggest, however, that the teacher should attempt to function as a therapist. If serious problems are indicated, the student should be referred to professional help.

The teaching team then should meet periodically to pool its knowledge about individual students and determine what steps are required in both individual and group situations to help overcome problems and to meet objectives. The meetings should include the school's guidance counselors, paraprofessionals, and streetworkers, if any. The streetworker, with his ability to work with students in the lounge or other non-classroom situations, can play a critical role in the guidance effort.

The use of teachers and streetworkers as counselors will help overcome a major problem in most guidance programs, the fact that both staff and funding usually are inadequate to do more than deal with paper work, emergency situations, and serious discipline problems. And it should help to orient the total school program toward the needs of the individual rather than to the mechanical coverage of a fixed body of subject matter.

The problem in handing teachers a guidance function is one of developing their ability to really listen to the student. Here, the theories of Dr. Thomas Gordon may prove helpful. Dr. Gordon, in a book entitled *Parent Effectiveness Training*, advocates what he calls "active listening,"

a process that requires certain basic attitudes on the part of a parent or a teacher:

- The desire to hear what the child has to say.
- The willingness to help with a particular problem when it is mentioned.
- The ability to accept the child's feelings even if alien to yours.
- A feeling of trust in the child's ability to handle his feelings and find solutions.
- The ability to recognize that feelings are transitory, not permanent.
- The ability to recognize that each child is an individual and that, as such, his feelings are deserving of respect.

Help also may be available from local colleges and universities, not only their schools or departments of education but their departments of sociology or psychology. University faculty people may be employed to help develop guidance skills among mini-school teachers. And university students can be employed directly in the guidance effort, receiving academic credit for their work.

The guidance program should deal with three major areas of concern—student values, decision-making ability, and career orientation. In the last, the effort should not be to

hand the individual a preconceived career objective, then counsel him in the strategies for achieving it. Rather, the objective should be to develop in the individual the skills and strategies that will help him discover—and rediscover—his own career objectives in a changing world. In other words, he should emerge with the ability to deal with the future. And these skills should be developed early—probably by the ninth grade—before the college option is closed off by election of a commercial, vocational, or other non-college-preparatory program.

The career-guidance effort can and should be woven into the mini-school curriculum. In English, for example, students can be trained in interview procedures and/or resume writing. Interviewing procedures might be the subject for a role-playing session in which students act out the roles of interviewer and interviewee, then watch their performance on videotape.

The opportunities for integrating the guidance function into the school program are nearly unlimited. For examples, see the following list, developed by Peter Read of the Sociology Department, Graduate School, City University of New York:

# J. L. ROSS,

Dealer in OAK, ASH, CHERRY, BLACK WALNUT, BIRCH,  
MAPLE, WHITE, and BASS WOOD, &c.



*Boston Directory 1848-49*

**MANUFACTORY FOR SCHOOL FURNITURE.**

**JOSEPH L. ROSS, Practical Manufacturer of DESKS and CHAIRS for Schools.**  
Hawkins, corner of Ivers Street, Boston.

## CLASSROOM ACTIVITIES RELATED TO CAREER DEVELOPMENT

### I. SELF-EVALUATION

- 1) In response to the question "WHO AM I?" have students write down ten different completions to I AM \_\_\_\_\_. Then discuss what categories students used—why are first most important, last least? Were there things they didn't want to mention? Did they take it seriously? What is the nature of the responses? What, if you asked I WOULD LIKE TO BE?
- 2) Spend one class each on the different self profile materials—discuss the nature of each evaluation and possible answers before having each student fill out his response. Object is to know self and potential for future.
  - Attitudes toward education
  - Attitudes toward work conditions
  - Self analysis—strengths and weaknesses
  - Specific occupations
- 3) Future orientation discussion—discuss what students think the world will be like in 20 years—what will be different, the same—then how they see themselves in it. Changes external—changes internal?

### II. DECISION MAKING

- 1) Have students list 10 decisions they have made or will make in the course of the day (today). If difficult give examples (watch TV or homework) attend class, or cut, go to school, what to do after school, etc. Then discuss which decisions they consider most important and who and or what will determine the outcome of the decisions.
- 2) Have students list quickly and privately 20 things they like to do. Then have them rate these things according to following categories; Do alone or with others; Cost more or less than \$5; Do in Public; Were doing 2 years ago; Father does; Mother does; Date of last time doing it; How often do it in a year; rank the top 5. Then discuss what they learned about themselves and if anything was surprising to them.
- 3) If you had one year left to live what would you do and why?
- 4) Have students fill in an hour by hour time chart for how they spent the last Saturday and Sunday—Then discuss what values are implied by the activities.
- 5) Have students list ten things they want to accomplish this year—why? and how?
- 6) What alternatives exist upon graduating from high school? Which to choose and why.

7) Employ situations involving risks to initiate discussion of values. e.g.: Which of the three jobs would you choose and why?

Low income but secure	Good income 50-50 chance of keeping it	High income - can keep it if do well, otherwise lose
A	B	C

### III. CAREER PLANNING

- 1) After assessing the range of occupations which a group of students aspire to, discuss the relationship of education (current and future) to these occupational goals—what about other things one must do to get where one wants to be?
- 2) Use the *occupational outlook handbook* to present trends in occupations of interest and to provide relevant recent information about possible careers.
- 3) What provides the motivation for a career—do students aspire to be like someone?
- 4) Life Career Game.

### IV. COLLEGE PLANNING

- 1) What does college mean to students—what do they think a typical day and course is like? What should they major in, why?
- 2) To what extent do students enjoy or are good at reading, writing, studying, independent work?
- 3) What are some survival strategies and techniques for passing or obtaining good grades in college?

### V. PRESENTATION OF SELF SKILLS

- 1) Role play interviews—college and jobs, have teams prepare questions and responses—use video tape—develop a super interview and interviewee. Analyze successful ways to present yourself on paper and in person.

Gordon, Dr. Thomas, *Parent Effectiveness Training: The Tested New Way to Raise Responsible Children*. New York, Peter H. Wyden, Inc. 1970. \$7.95

## PROMOTING INTERACTION AND GROWTH

As should be obvious by a reading of this handbook, the process of restructuring a school will involve a considerable amount of time spent in planning meetings and/or in training programs. A major problem, then, is to insure that such time is productively utilized. Meetings can result in important achievements or they can lapse into aimless discussion and amount to a total waste of time. And the same thing can be said for training programs.

In both cases, it is essential to have a very clear idea of your objectives, of what it is the meeting or training program is to accomplish. The objectives then must be translated into an agenda setting forth a series of steps required to meet the objective and assigning responsibility for each item and setting an estimated time allocation for each step. If possible, achieve a consensus beforehand among meeting participants on overall objectives and on specific agenda items, and use the meeting to make decisions and plan for their implementation.

Once the meeting is convened, its success in meeting objectives will depend largely on the leadership capabilities of the chairman or discussion leader. He or she should

be willing to listen to all opinions—planning should be a democratic process. Where participants do not volunteer their opinions, the chair should actively solicit them. On the other hand, the chairman should be firm and goals-oriented, capable of holding the discussion to objectives and the agenda and insuring forward motion. He or she should review all decisions before the meeting disbands.

In planning a meeting or training program, remember that the physical setting can have an important impact on its effectiveness. Unless the group is too large, a meeting "in the round" is far preferable to an arrangement in which the chairman confronts rows of seated participants from a podium. Interaction will be enhanced if all participants face each other across a table—round is preferable but a square one will do. If at all possible the typical, rectangular configuration of the corporate board room table should be avoided. If it can't, the chairman should sit on one side of the table, *not* at its head.

Before the meeting, seating around the table should be provided for somewhat fewer people than are expected to attend. Later arrivals then will be obliged to draw up extra chairs from the side of the room. The effect will be to lend a sense of importance and urgency to the proceedings. In contrast, empty chairs around the table will suggest that not much importance has been accorded to

the session and many have chosen to stay away.

Pay attention to the total environment in the meeting room. Is the temperature right (cooler is preferable to warmer)? Is lighting adequate? Can noise from adjacent rooms or the outdoors be excluded? Is there insurance against such interruptions as telephone calls? Is there provision for note-taking by participants? Is there provision for visual presentations—chalk boards, display easels, audiovisual equipment? If audiovisuals are to be employed, is the equipment in working order? Is a trained operator available? Are visual materials of adequate size and clarity to be read and understood by everyone in the room? These may seem to be obvious questions. But the sad fact is that they often are overlooked, to the detriment of many a meeting or training program.

## THE INFORMATION FACTOR

Critical to the process of gaining acceptance and support for any educational reform is the effective dissemination of information to everyone concerned with the project. It is necessary to inform not only the immediate school community—faculty and students, the community school district, immediate superiors at school headquarters, parents—but to reach such involved people as consultants, con-

tacts at local universities, foundations, interested corporations, the local teachers' union or association, service organizations like New York's Public Education Association, and the local news media.

As the diversity of the above list suggests, communications with different groups will vary both in content and frequency. The school community obviously has a more direct concern with the proposed reforms and will need to be kept fully informed through frequent and reasonably detailed memoranda and reports on decisions and progress. Outside, but involved, individuals and organizations will require less detail and probably will lack the time to digest it. That audience probably should be reached through an occasional letter or newsletter informing them in general terms of project accomplishments.

Accordingly, early in any reform project, a comprehensive mailing list should be developed. Each listing should be categorized according to the type and frequency of the communications it is to receive. A communications schedule then should be developed, establishing the nature, frequency, and audience for each type of mailing.

Regardless of the audience, all communications to the school's constituency should be clear, easy to understand, and to the point. Remember that not everyone in your



audience is an educator or familiar with educational jargon. Avoid professional or technical language. Stick to simple, straightforward prose that tells your story briefly and effectively. To the extent possible, avoid the dull and technical approach of numbered sub-paragraphs and sub-sub paragraphs.

The secret here is to place your communications program in charge of an individual on the school staff or in the community who, by background or inclination, has the ability to translate project developments into clear, readable prose of interest to professional and layman alike: In communicating with the student body, it will be helpful to find a student with the same capabilities.

Remember that written communications represent only part of the overall information effort. Communication also will occur at meetings and in training programs. Refer to the preceding section, "Promoting Interaction and Growth," when considering your total program.

As suggested in the opening paragraph of this section, the information flow should extend to the local media. But contact with the media should be handled with great caution. Remember that, until it proves itself, any school project is an experiment. Make sure that the media understand that fact and that neither you nor the media greet

the new project with extravagant claims about its ultimate impact on the school or on education in general

Suggestions that the project will "revolutionize schooling" are dangerous. If resulting expectations are not realized or realized only partially, the claims can come back to haunt you and can do irreparable damage to the credibility of both the project and its supporters.

Even worse are suggestions that a project will "save the school" from itself and, more particularly, a "difficult" student body or an "inadequate" faculty. Such publicity can only serve to alienate the very people who must accept and help implement the proposed reforms.

Publicity, in short, can be an effective means of communicating with your community. But it is a tool that should be used judiciously.

## THE DIPLOMACY OF CHANGE

Any effort to promote change within a school, whether it be from within the school or by an outside agency, requires strategy, an approach that will win the acceptance and support of all those involved. In other words, diplomacy is called for. The strategies for in-school efforts to

promote change—particularly the establishment of a school development team—are discussed in detail earlier in this handbook.

But the strategies required if an outside agency like the New York Urban Coalition is to intervene successfully in school affairs merit some discussion. Such agencies are likely to be regarded by school faculties as both "outsiders" and "non-professionals." Their efforts to help can easily be misinterpreted by the staff as "interference" in school affairs.

Essentially, there are two basic intervention strategies. One is to start at the bottom by establishing partnerships with school staff members, working with them to gain acceptance and credibility for a project before seeking the approval and support of higher echelons.

The second is to start at the top by "selling" the project to senior board of education officials and encouraging them to decree that the school or schools adopt the proposed reforms.

The first approach clearly is preferable, in that, from the outset, those who must implement the reforms are involved in the decision-making process.

The second tack courts disaster. Reforms imposed from

above seldom "take" largely because there is no system of accountability by which to enforce directives from above. Teacher resentment, apathy, or non-cooperation usually will insure their failure.

But experience indicates that the best strategy may be careful orchestration of the two approaches. The project should start at the school level. But, almost simultaneously, alliances should be formed with key people at the top level of the school district administration. The objective will not be to suggest imposition of reforms but to secure a level of interest and support from the top administrators that will lend credibility to the project and the potential for impact outside the project school.